

# GT4000 LCD Topper & GT4010 LED Backlit Topper

## Technical Specification

Issue: 10



  
Gamesman

**Contents:**

***Introduction.....3***

***General Topper Assembly.....4***

***Topper Connectivity.....5***

***Input Voltage & LED Control Connection.....5***

***LCD Connection.....6***

***Onboard Graphics Media Player.....6***

***Topper Electrical Ratings.....8***

***LED Sequence Routines.....9***

***Functional Instruction.....9***

***Modes.....10***

***Mode Sequences.....11***

***Topper Dimensions.....12***

***Artwork Template.....14***

***3D CAD Data.....15***

***LCD Screen Spec Summary.....15***

***Base Options.....16***

***Finishes.....16***

***Towerlight.....16***

***Artwork Replacement.....17***

***Configurator/Specification Sheets.....19***

***Appendix A; LCD Specification***

***Appendix B; RS232 Communication Protocol***

***Appendix C; GT4000 EDID Settings***

## **Disclaimer:**

The information provided within this manual is intended only to make the reader aware of the product's technical data and its use thereof. As such, Gamesman Ltd shall not be held liable for any loss or damage to the assembly or component within, arising from its misuse or from the unintended use of information or particulars included within, or any omission from, this document.

Design and specifications are subject to change without notice.

Failure to observe the interface requirements specified in this document may result in damage to the electronics and resultant performance characteristics of the product.

## **Document Revision Control:**

<b>Issue #</b>	<b>Date Released</b>	<b>Specific Changes</b>
01	29.03.12	Released from Issue 'Draft'
02	05.07.12	RS232 Communication Protocol added (Appendix C) Assy P/N GFA02320 added
03	09.08.12	Video input resolution data added (Appendix D)
04	04.09.12	GT4010 pin outs added - now accepts 12v or 24v Input
05	15.07.13	Towerlight adapter option added
06	17.03.14	GT4000 onboard memory/media player option added
07	01.04.14	Candle extension cable pin-out added
08	04.08.16	High brightness panel option added LED sequence selection section updated
09	20.06.17	RGB LED functional instruction section updated Configurator sheets updated
10	30.10.17	Configurator sheets updated

## **Introduction:**

The GT4000 & 4010 Toppers are our latest in a wide range of exciting topper products. The GT4000 is a fully controllable 18.5" LCD topper and the GT4010 consists of a backlight matrix of bright white LEDs. They are both designed to be mounted on top of gaming machines/cabinets within the casino and/or AWP sector. The topper fundamentally acts as an initial attention grabber, as well as having the ability to promote the machine in question and conveying the game's design intent.

Gaming manufacturers utilising this topper design should expect to see heightened game pleasure and positive feedback from consumers.

The main benefits of the Gamesman GT4000 LCD and GT4010 LED Topper include:

- Injection moulded components for strength and durability
- Bright RGB periphery bezel illumination
- Bright white backlight matrix to illuminate the GT4010 central artwork
- Good variety of standard (or custom) RGB LED sequences
- RGB sequences selectable via manual rotary switch board (available as a separate orderable item) or through live gameplay via RS232 communication protocol
- 12v / 24v DC Input
- Optional standard mounting base or custom designs to suit your specific cabinet
- Towerlight compatible – blanking plate supplied and an optional adapter kit fitted for classic round candles
- Stream video/graphics on the high quality 18.5" 16:9 LCD TFT standard (LED Backlit) screen or high brightness version
- VGA, DVI-D and HDMI video connectivity options for LCD connection
- Media player option for locally stored on-board flash memory for LCD graphic content (SD Card, Compact Flash, USB stick compatible)

**General Topper Assembly:**

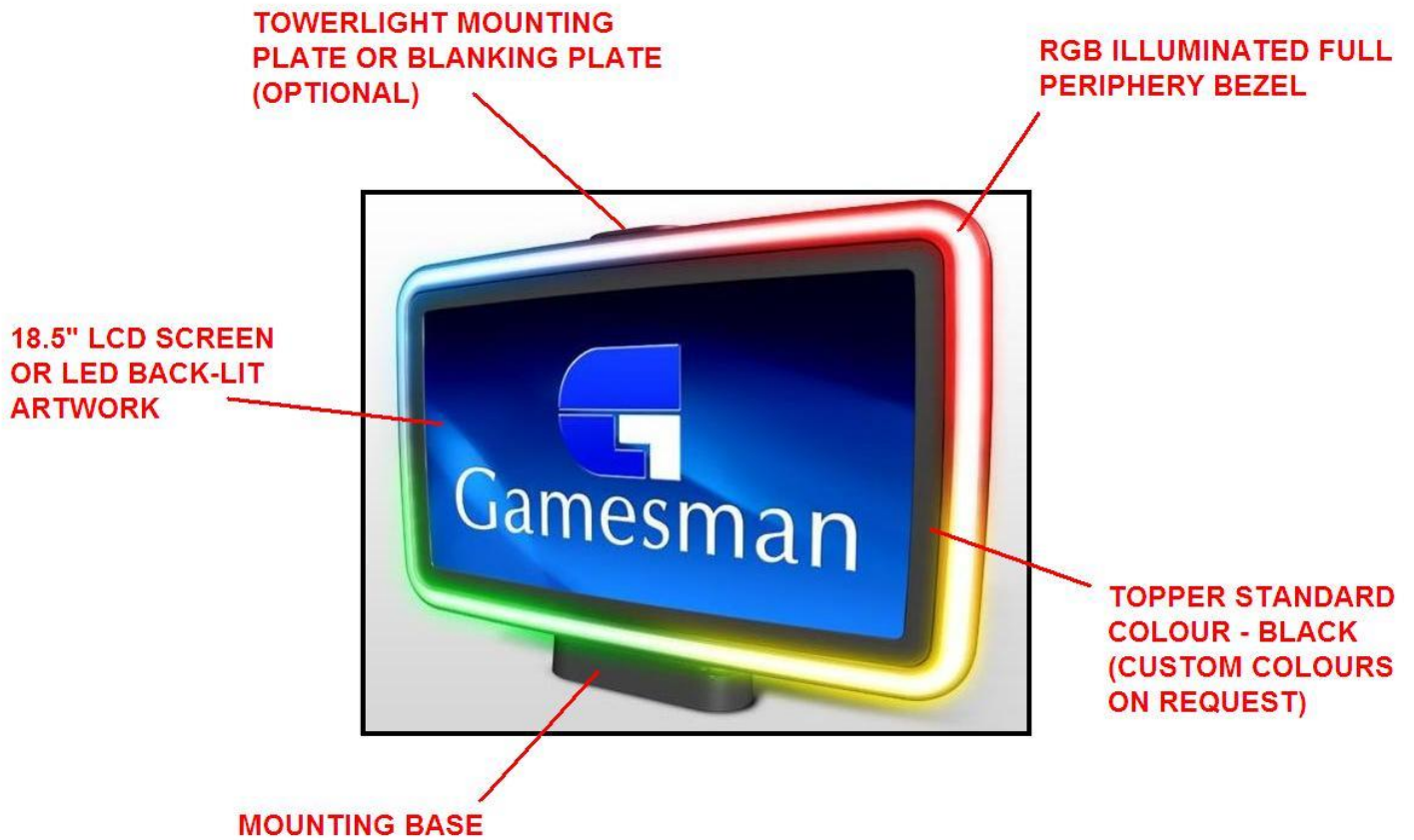

## Topper Connectivity:

### - Input Voltage & LED Control Connection

The topper will be supplied with a main harness that exits from the bottom with two connectors. The 12way connector has the following pin-out configuration for connection to the cabinet. Both the GT4000 & GT4010 can be supplied with 12v and/or 24v, assuming the correct configuration option is selected at the time of ordering (see configurator sheets on page 19 & 20).

### GT4000 24v Version Only

PIN #	FUNCTION
1	24v
2	24v
3	SPI GND
4	SPI SS
5	SPI SDO
6	RS232 RX

PIN #	FUNCTION
7	GND
8	GND
9	SPI SDI
10	SPI SCK
11	RS232 GND
12	RS232 TX

### GT4000 & 4010 12v & 24v

PIN #	FUNCTION
1	12v
2	24v
3	SPI GND
4	SPI SS
5	SPI SDO
6	RS232 RX

PIN #	FUNCTION
7	GND
8	GND
9	SPI SDI
10	SPI SCK
11	RS232 GND
12	RS232 TX

**Connect pin#1 OR pin#2 - NOT both**

This 12way connector p/n on the harness exiting the topper is:

Molex Housing P/N: **43020-1201**  
Molex Terminals P/N: **43031-0001**

To connect to the Gamesman harness, the customer requires:

Molex Housing P/N: **43025-1208**  
Molex Terminals P/N: **43030-0001**

The other smaller 6way connector exiting the topper is to connect the Gamesman RGB Periphery LED Sequence Switch PCB that enables the customer to manually change the LED bezel sequences and colours. More details on this can be found on page 9.

- **LCD Connection**

Video content can be streamed to the LCD via VGA, DVI-D or HDMI. Such cables will be included with the topper upon selection of the required Cable through the Topper Specification Sheet, and exit from the bottom along with the aforementioned main harness. The optimum resolution for graphics/video is 1366 x 768 (see full LCD spec within this document for more info). The connected PC (or media server) should therefore be set to output this resolution. The internal LCD AD board will not auto-scale or auto-adjust the image resolution.

- **On-board Graphics Media Player**

For those who cannot stream live graphics to the LCD from a central server or via the game, we have another solution available.

A media player option can be selected when ordering which enables the topper to display still graphics or video from a range of data inputs including:

- SD Card
- Compact Flash
- USB

These inputs are accessible on an extension board that exits the bottom of the topper along with the power cables. This input extension board is housed within a plastic moulding, the connection cables approx. 1m in length enabling it to be secured to the inside of the EGM where necessary;

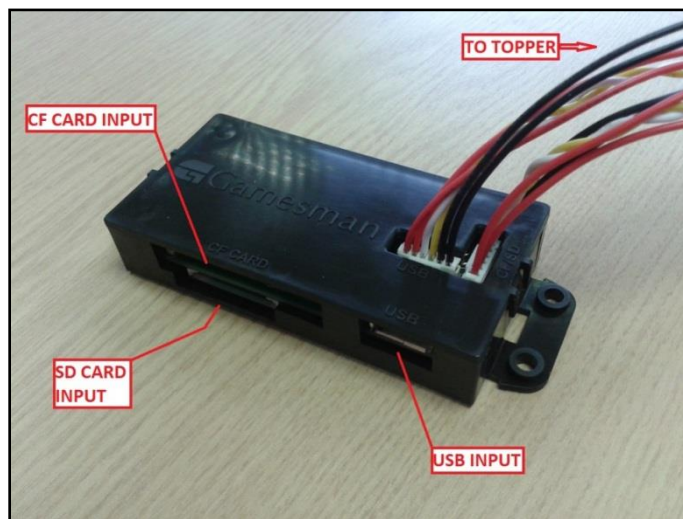

The content from one of the above listed formats will play on a continuous loop as long as it is plugged into the extension board. The graphics can be changed in the field by replacing the SD Card/USB stick/Compact Flash on site.

The topper will accept most of the common types of data file, listed in the main parameter table below;

<b>Support Format</b>	Video Format	MPG、MPG-1、MPG-2、MPG-4、AVI、MP4、DIV、TS、TRP、MKV、MOV、WMV、RM、RMVB
	Picture Format	JPEG、BMP
<b>Video Decode</b>	MAX resolution	1920*1080
	Color Depth	24bit
	Maximum frame	30frm/s
	MAX Data Rate	USB2.0 device:30Mb/s
<b>Power supply</b>		DC12V /300mA
<b>Power consumption</b>		< 3W
<b>USB Transmission speed</b>		USB2.0, Max 480Mbps

The media player extension input PCB is mounted within a cover moulding that includes fixing points to enable attachment within the cabinet. The mounting details are below;

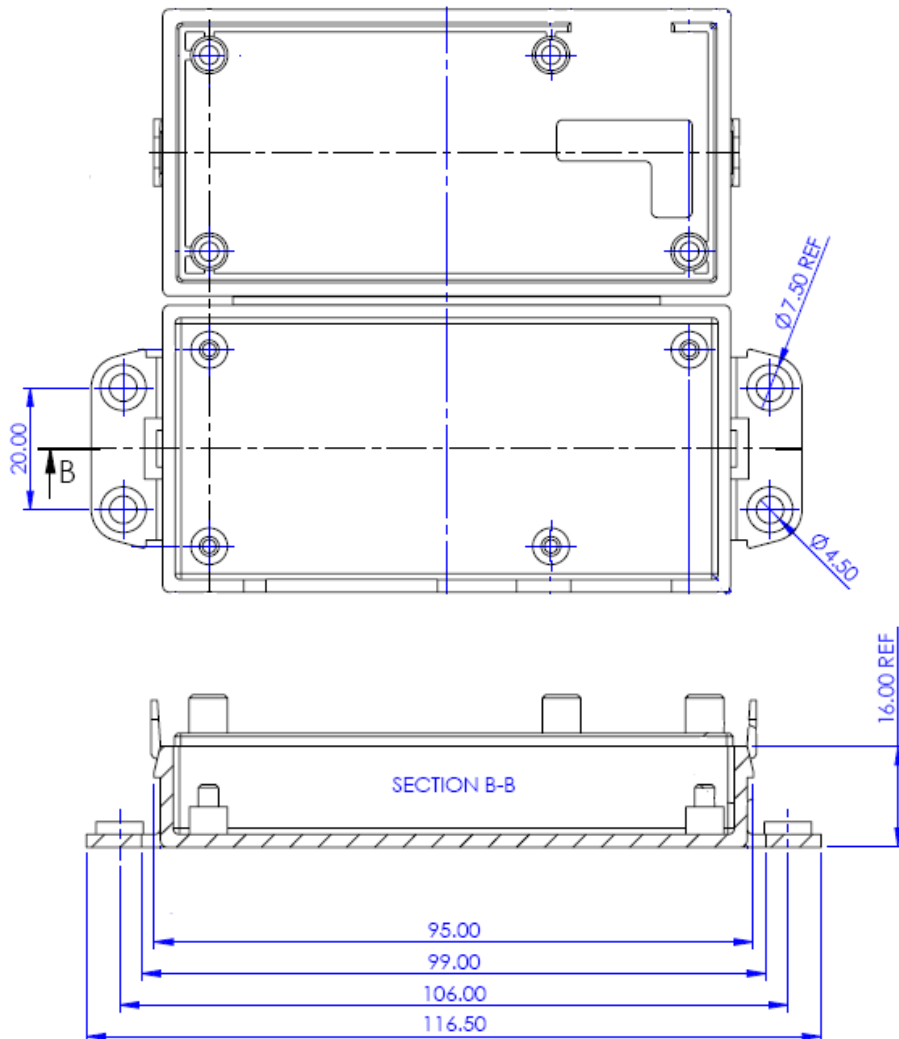



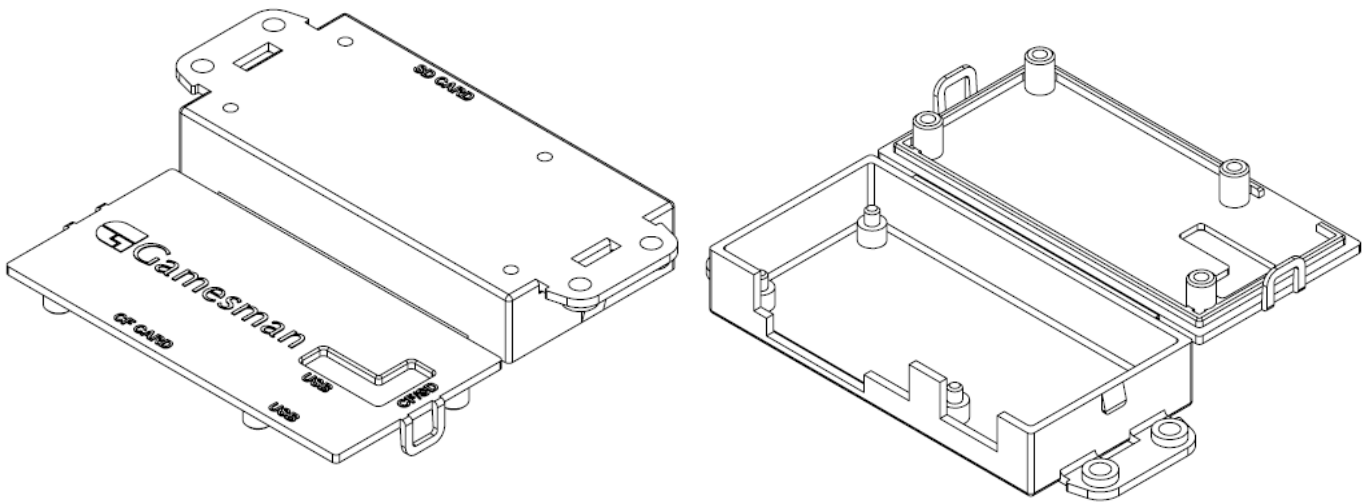

For any further information on this on-board media player feature please contact Gamesman.

### **Topper Electrical Ratings:**

Typical electrical ratings for both the LCD and LED Backlit toppers are shown below;

Parameter	Value
Max. Current Consumption - LCD	0.7A @ 24v
Max. Current Consumption - Bezel LEDs	0.5A @ 12v
Max. Current Consumption - Backlight LEDs	1.43A @ 12v
<b>GT4000 Max. Power Draw</b>	<b>22.80W</b>
<b>GT4010 Max. Power Draw</b>	<b>23.16W</b>

## LED Sequence Routines:

The topper bezel consists of x64 high quality RGB LEDs in both the GT4000 and GT4010 variants that completely surround the centre display and the topper can be supplied with a range of standard demo or customer-specific LED sequences loaded on-board at the time of manufacture.

For the GT4010 LED backlight variant, the x209 white central display LEDs are on/off only.

### - Functional Instruction

There are two methods of changing the RGB LED sequence and colours illuminating the periphery bezel of the topper as explained below;

1. **Manual Selection:** Plug in the switch PCBA (available to order separately) into the 6way connector on the topper harness. Press the black button for 3seconds to enter 'EDIT' mode, then turn the rotary dial to change the sequence from 0-9 and press the button to change the colours used in that sequence to your desired effect (95 colour groups available). **Turn the topper off and unplug the switch PCBA.** Upon power up, the topper will remember the last sequence and colour selected, and the same switch PCBA can be used to change another topper in the same fashion. To reset the topper to factory defaults, press and hold the colour button for 5 seconds.

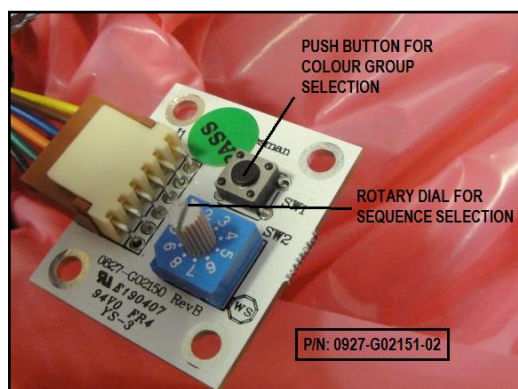

2. **RS232 Selection:** A stored sequence can also be selected during live gameplay by the host computer via RS232. Refer to the appendix section for this communication protocol.

**Important Note:** At the time of manufacture toppers are loaded with firmware which correlates to one of the above options. It is therefore important that the anticipated method of control is highlighted to the Sales team when ordering the top level topper assembly. The topper spec selection sheet can also be used to specify which option is required (see pages 19 & 20). It is possible to use the same firmware/topper to select sequences manually as well as via RS232 but the unit will only remember the last sequence used (if turned off and on again) for the appropriate matching method of control.

- **Modes**

The standard sequences pre-loaded into the topper are explained below:

- A) **Cascading Fountain:** All three colours are used, in the order they appear in the below table, in a 'fountain' effect in which the colours cascade from the top (centre) of the topper to the bottom, on both sides in blocked lines of colour approx. 100mm long. The colours generate from the top and disappear once they meet again at the bottom.
- B) **Tricolour Chase:** Three colours in each colour group illuminate 1/3 of the bezel - each in solid colour and chase round initially in a CW motion, before pausing and returning in an ACW movement.
- C) **Rotating Intermittent Flash:** One colour is used at a time rotating CW, with intermittent LED flashing. This animation uses each of the three colours of the specific colour grouping in the order they are listed below. The illuminated LED sections are larger than the non-illuminated LED areas, although all are equally spaced.
- D) **Double Colour Fill:** A small section (2 LEDs) lights up at the top and bottom of the topper & moves round in a CW direction. The background is a different colour and this colour is filled and covered with the small section colour from two directions until the topper is full of the small section colour.
- E) **Double Colour Chase:** A small section (2 LEDs) lights up at the top of the topper and moves down in two directions. There is another colour as background, the small section colour moves to the bottom of topper then returns to the top of the topper.
- F) **Double Colour Roll & Fill:** One colour as the background, then another colour begins to fill from three small sections (1 or 2 LEDs) in CW direction. Once the topper is full of the small section colour, it will return in ACW direction. Another mode: when the topper is full of the small section colour, the background colour will begin to fill in the same fashion (beginning with 1 or 2 LEDs) in CW direction and then return in ACW direction.
- G) **Single Colour Diffuse:** One colour is lit up in a small section in different areas of the toppers (bottom, top left and top right) and then begin to diffuse in two directions. Once the topper is full of this colour, it will reverse the animation and return to three sections. Three colours are used in a colour group.
- H) **Flag Mode:** Different national flags are displayed in a cycle, when the push button SW2 is pressed the flag changes in this order:

Italy	Russia	Spain	France	Austria
-------	--------	-------	--------	---------

- **Mode Sequences**

The below table shows what and how each sequence (and switch position) will perform. The letters in column 2 relate to the modes outlined above and automatically scroll from one to the other in the order listed (unless only one sequence is shown in which case it remains on that one sequence). All sequences/modes start with the default Green White Red colour group. This colour can be changed by pressing the push button switch and after 5 seconds, the selection will be stored in memory.

Switch pos.	Sequence	Colour group,	Notes
0	A B C G	GWR,RGB,RYW,RWB,RCY	
1	D E F	ONLY BLUE WHITE	
2	A	GWR,RGB,RYW,RWB,RCY	
3	C	GWR,RGB,RYW,RWB,RCY	C is LIGHT BLUE
4	A B C G H	GWR,RGB,RYW,RWB,RCY	
5	G	GWR,RGB,RYW,RWB,RCY	
6	H	ITALY, RUSSIA, SPAIN, FRANCE, AUSTRIA	
7	A B C D E G H	GWR,RGB,RYW,RWB,RCY	D & E, - BLUE & WHITE
8	B	GWR,RGB,RYW,RWB,RCY	
9	A B C D E G	GWR,RGB,RYW,RWB,RCY	D & E, - BLUE & WHITE

Please contact us if you wish to request any custom sequences (or specific flag colours etc). We can store a maximum of 10 full sequences on the standard topper memory chip (specific sequence length and complexity dependant). This even includes constant static full colour modes.

## Topper Dimensions:

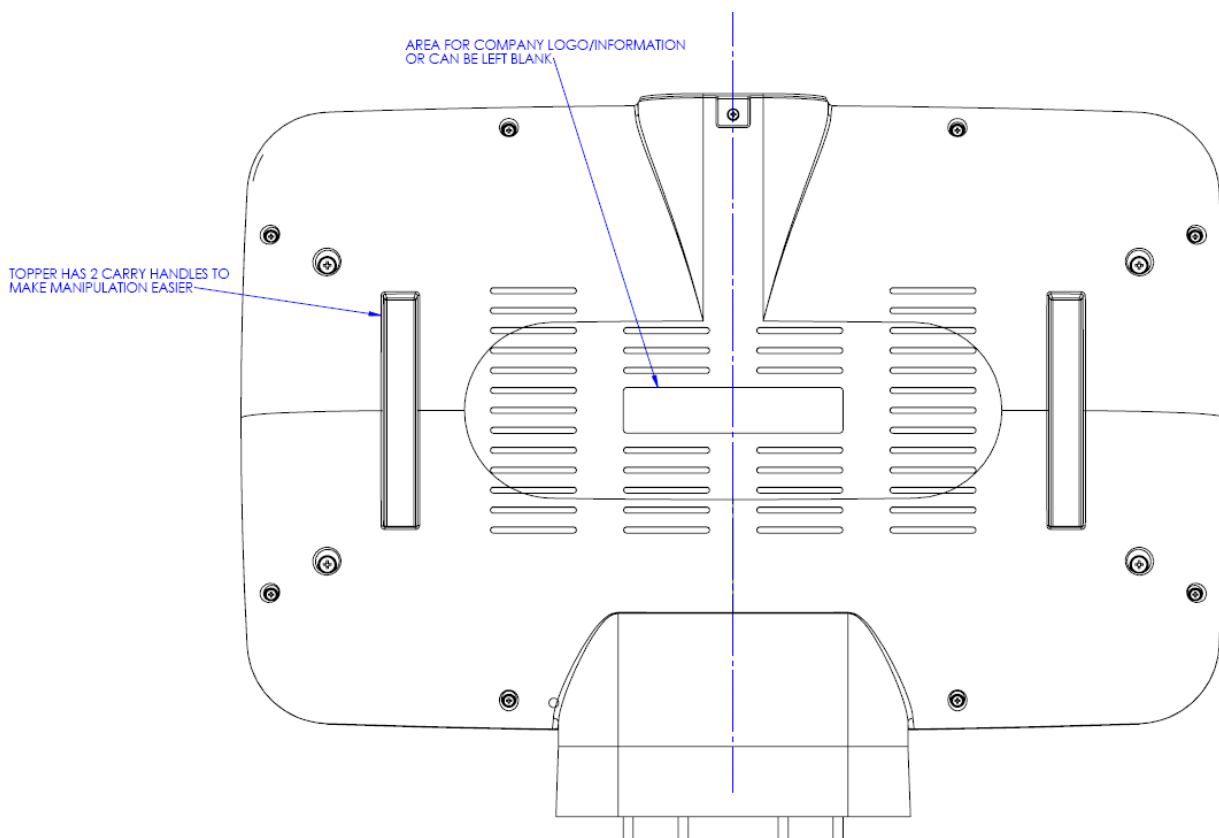
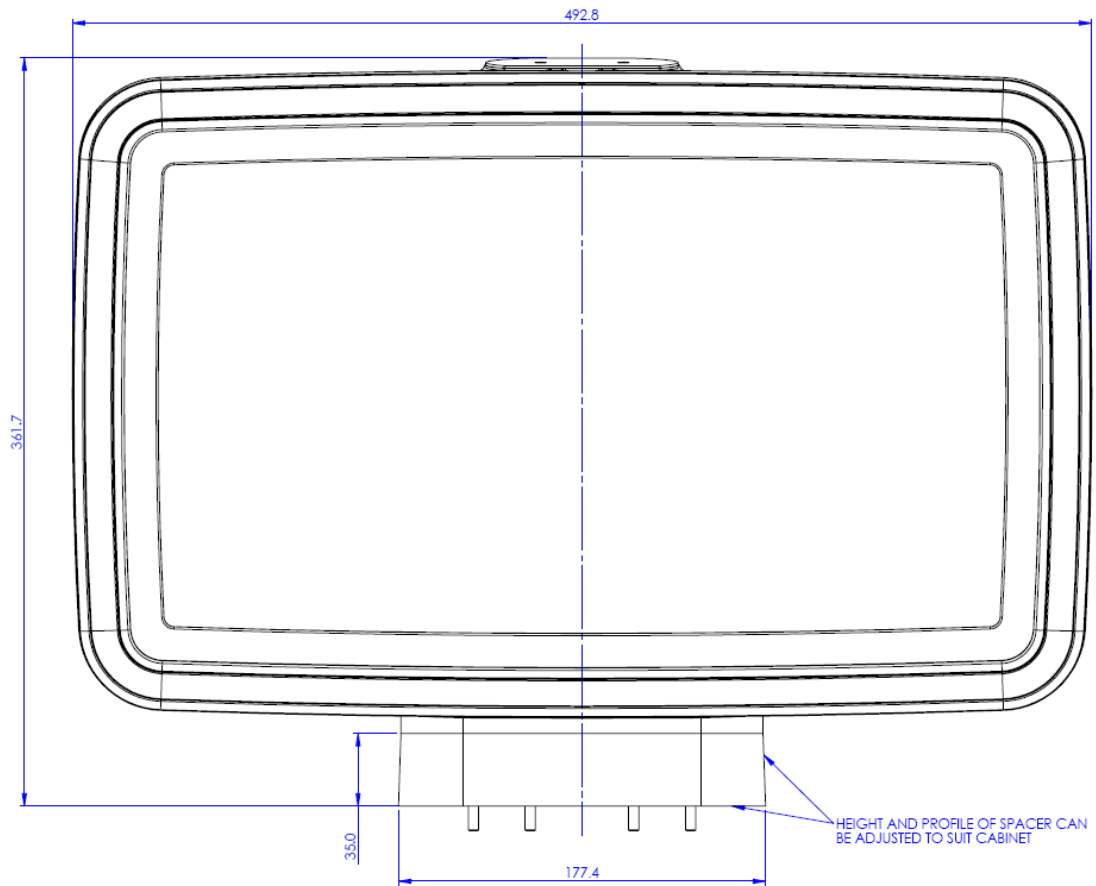

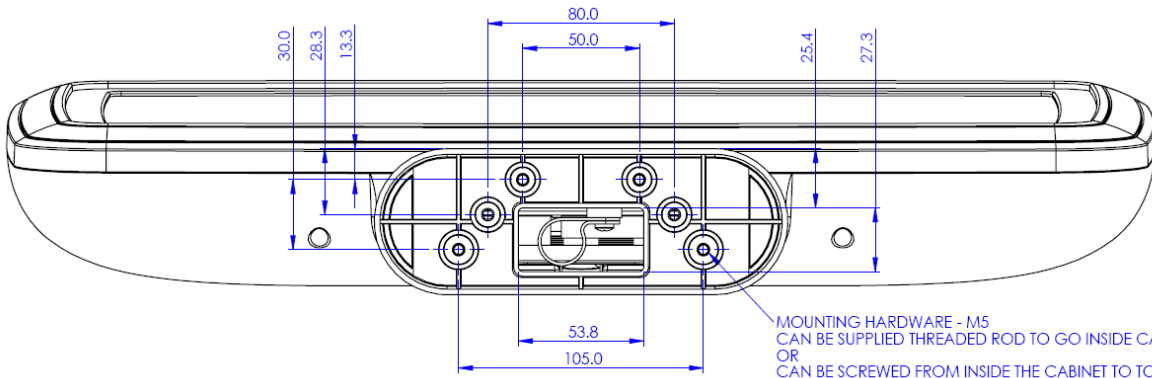

MOUNTING HARDWARE - M5  
 CAN BE SUPPLIED THREADED ROD TO GO INSIDE CABINET  
 OR  
 CAN BE SCREWED FROM INSIDE THE CABINET TO TOPPER (LENGTH CRITICAL)

CAN BE SUPPLIED WITH VARIOUS TOWER  
 LIGHTS OR A BLANKING PLATE

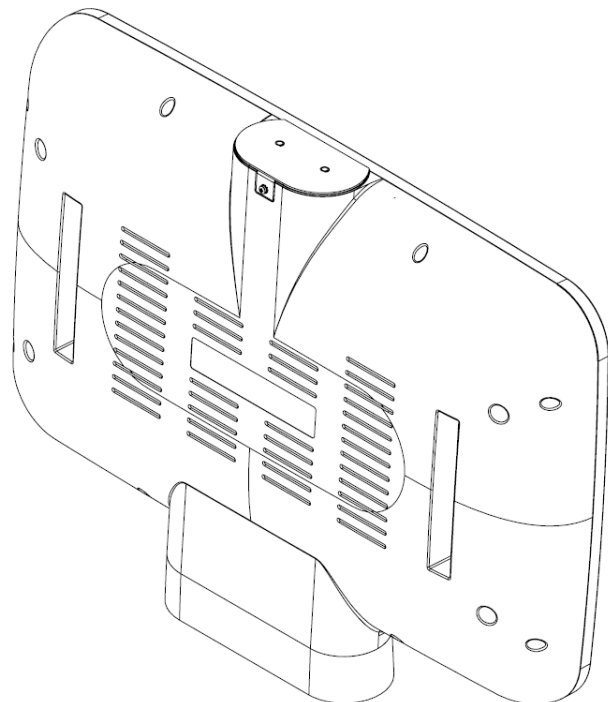
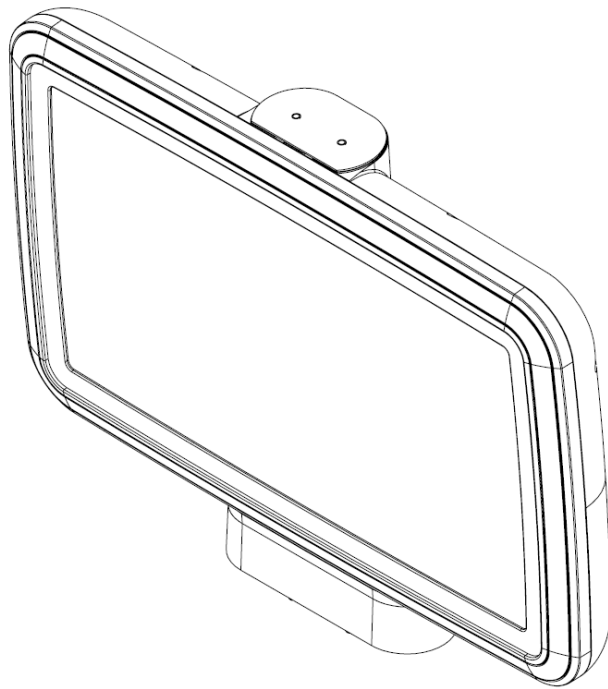
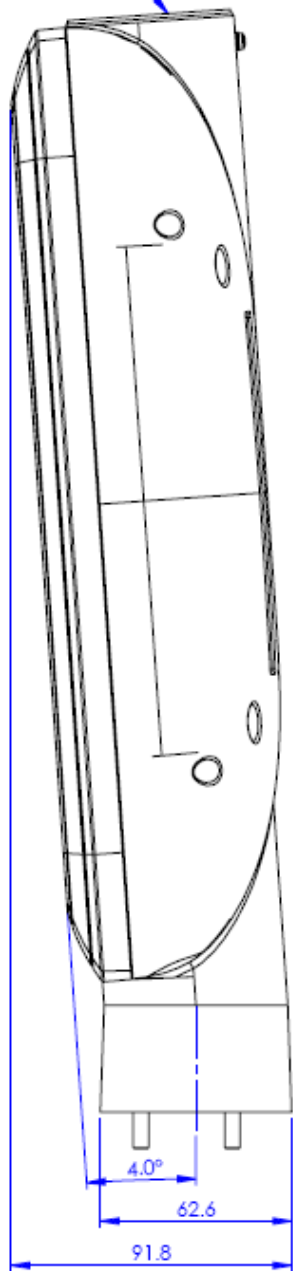

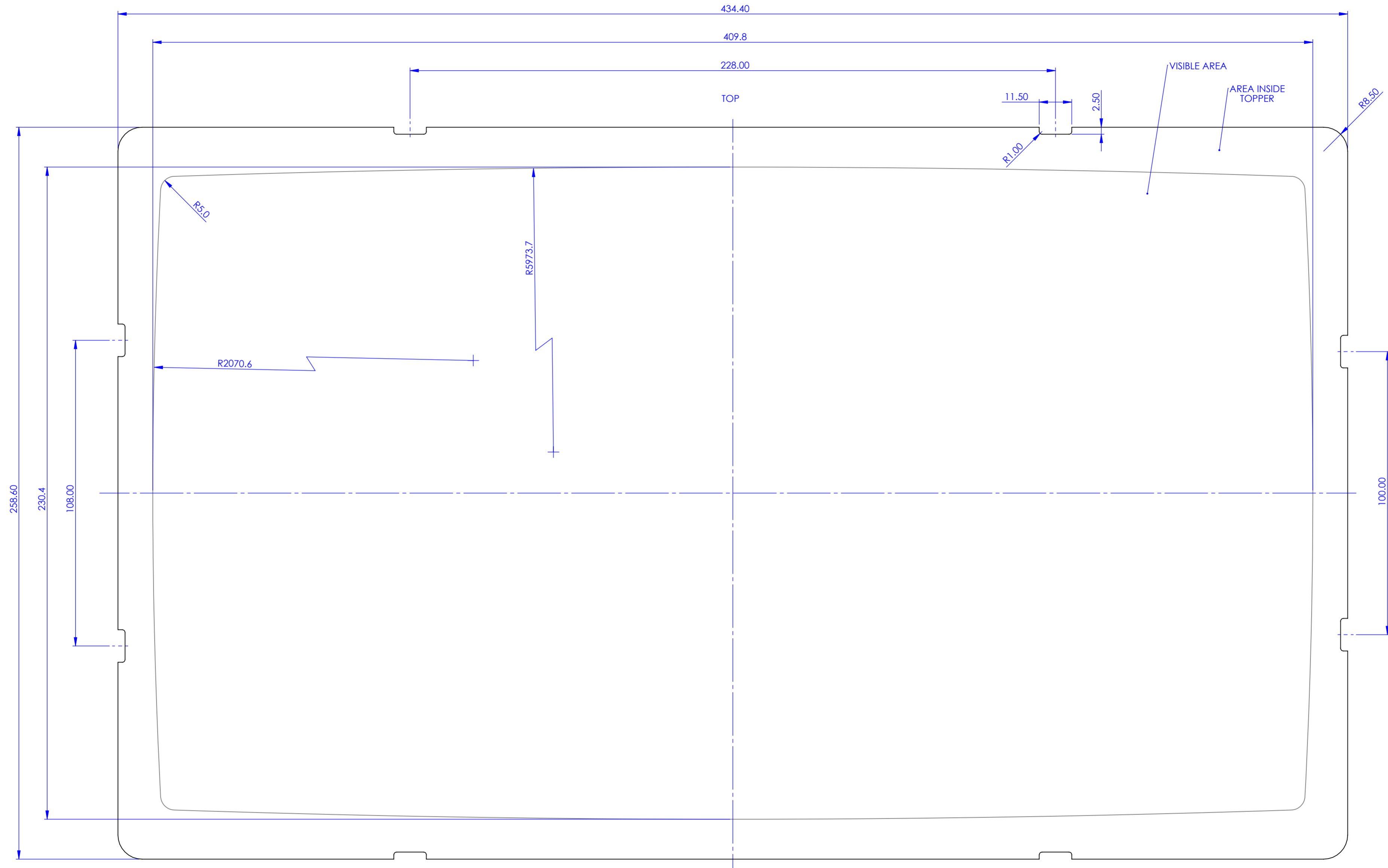

NOTES:

- 1. MATERIAL - 3.00 THK ACRYLIC SHEET
- 2. FINISH - NONE
- 3. DRAWING VIEWED FROM PLAYERS PERSPECTIVE OUTSIDE OF TOPPER (PAINT TO BE ON INSIDE)

APPROVED	<p>Unit 6, Crompton Fields, Crompton Way Crawley, West Sussex, RH10 9QB, UK Tel: +44(0)1293 418888 Fax: +44(0)1293 418880 <a href="http://www.gamesman.co.uk">http://www.gamesman.co.uk</a></p>	THIS PART MUST BE RoHS COMPLIANT	DIMS mm	SCALE 1:1	2 24/07/2013	ECN-1524	DIMS ADDED FOR VIEWABLE AREA	R.LOFFLER
DRAWN R.LOFFLER		FINISH SEE NOTES	TOLERANCES UNLESS OTHERWISE SPECIFIED: 0.00 DIMS ±0.13 0.0 DIMS ±0.40 ANG +0.5° DRAFT ±1° PER SIDE CONCENTRICITY ±0.08 MAX ○ - DENOTES INSPECTION DIMENSION	ISS. DATE	1 28/03/2012	NEW DRG	DRAFT ISSUE	R.LOFFLER
DATE 04/04/2011		MATERIAL SEE NOTES		TITLE GT4010 LED BACKLIGHT TOPPER ARTWORK TEMPLATE	SIZE A2	SHEET 1 of 1	DRAWING No. GFP01901	NAME

## 3D CAD Data

3D simplified CAD Data of both the GT4000 LCD and GT4010 LED Backlight Toppers are available upon request. Please contact Gamesman directly if you wish for these files.

## LCD Screen Options

During 2016 Gamesman has introduced a new 'Enhanced Brightness' specification screen as an option alongside our original 'Standard Brightness' panel. This new screen utilises all the same successful features found on our existing panel but now with an increase in 'White Luminance' from 250cd/m<sup>2</sup> to 350 cd/m<sup>2</sup>(Typ) along with enhanced viewing angle.

***To discuss samples of the new 'Enhanced Brightness' GT4000 please contact one of our sales representatives.***

## LCD Screen Specification Summary

Below is a table listing the main specifications of the 18.5" TFT supplied within the GT4000 Topper. A full specification can be found in Appendix A.

ITEMS	Unit	SPECIFICATIONS
Screen Diagonal	[mm]	470.1(18.51")
Active Area	[mm]	409.8 (H) x 230.4 (V)
Pixels H x V		1366(x3) x 768
Pixel Pitch	[um]	300 (per one triad) x 300
Pixel Arrangement		R.G.B. Vertical Stripe
Display Mode		TN Mode, Normally White
White Luminance ( Center )	[cd/m <sup>2</sup> ]	250 cd/m <sup>2</sup> (Typ.)  (350 cd/m <sup>2</sup> High Brightness Option)
Contrast Ratio		1000 (Typ.)
Optical Response Time	[msec]	5ms (Typ., on/off)
Nominal Input Voltage VDD	[Volt]	+5.0 V (Typ)
Power Consumption (VDD line + LED line)	[Watt]	VDD line: PDD (typ)= 1.75W, All black pattern at 60Hz LED line : PBLU (typ) = 7.2W Total : 8.95W
Weight	[Grams]	1290(Typ)
Physical Size	[mm]	430.4 (W) x 254.6 (H) Typ. x 9.9 (D) Typ
Interface		One channel LVDS
Support Color		16.7M colors (RGB 6-bit + Hi_FRC )
Surface Treatment		Anti-Glare, 3H
Temperature Range Operating	°C	0 to +50
Storage (Shipping)	°C	-20 to +60
TCO6.0 Compliance		Yes



## LCD EDID:

The standard EDID settings used on the GT4000 is shown in Appendix C.

## Base Options:

The standard base is flat. Please refer to the dimensional section for more info. Please contact us if you wish to discuss a custom base option to fit your desired cabinet. The shape and mounting positions can easily be changed to suit your needs by way of a separate adapter.

## Finishes:

The topper bezel lens is an opal translucent white to allow the RGB LEDs to illuminate through and so as to reduce hot spot areas. The rear of the topper, including the base and towerlight blanking plate or adapter is black, as is the topper front bezel. If you wish to discuss custom colour or finish requirements such as chrome, gold or PVD plating/spraying of the front bezel – don't hesitate to enquire.

## Towerlight:

Gamesman does not supply a standard towerlight for use with this topper. However, we can provide toppers with an adapter mount kit, effortlessly allowing the fitment of 'classic' round candles available separately within the marketplace. The candle is secured to the top adapter plate with two fixing nuts and the existing candle harness is plugged into a connector mount also accessible within the top of the topper. An extension harness brings the connection through and out of the bottom along with the other connection cables. The dimensions of the adapter plate are shown below to verify compatibility along with exiting connector:

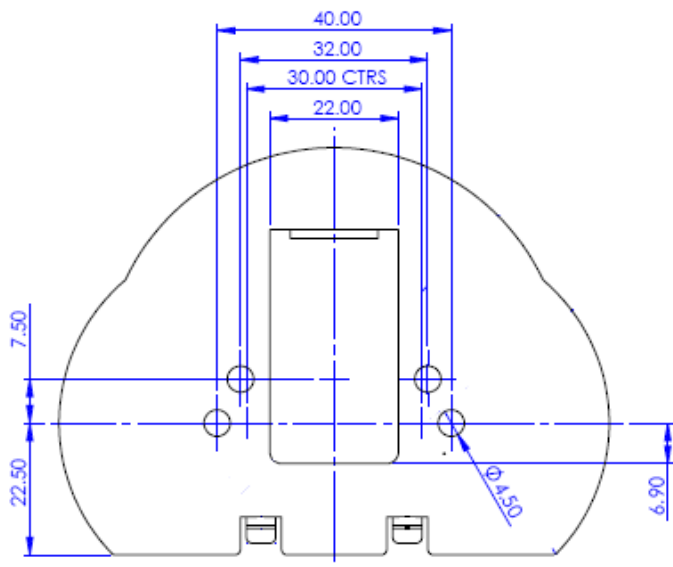

CONNECTOR: MOLEX PART# 03-09-1040  
TERMINALS: MOLEX PART# 02-09-1117

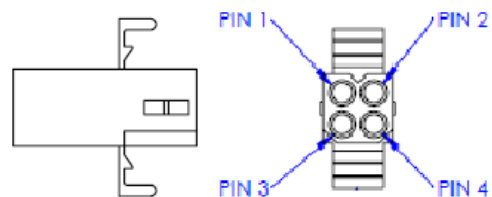

PIN #	WIRE COLOUR	FUNCTION
1	BLACK	+12V DC
2	RED	MIDDLE LAMP
3	BLUE	BOTTOM LAMP
4	YELLOW	TOP LAMP

Additionally, a blanking plate is supplied if no towerlight is required.

## GT4010 Artwork Replacement

The photo's below show how to replace the artwork within the GT4010;

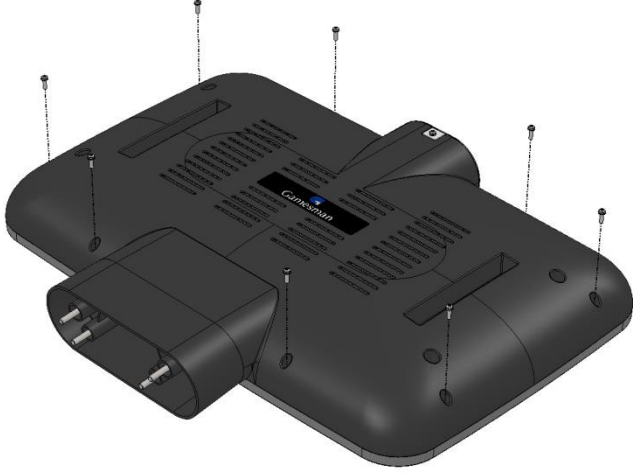
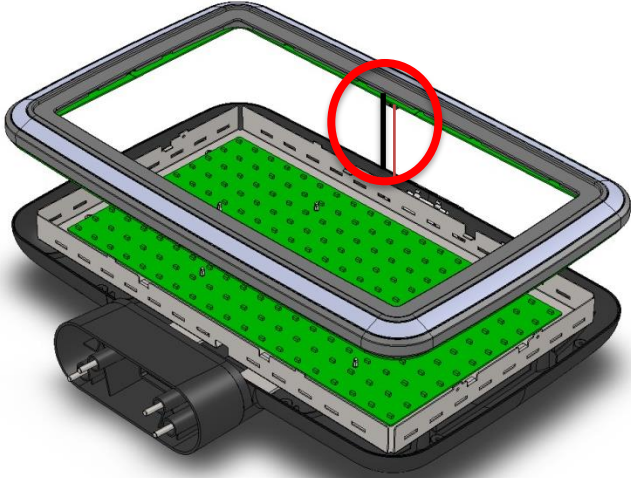
Operation ID	Description	Notes
1.	Place Topper face-down on flat workbench surface and remove the 8 screws shown.	 A perspective view of the GT4010 Topper assembly, which is a black plastic component with a central display area. Eight screws are indicated by thin lines pointing to their locations on the top surface of the device.
2.	Flip assembly over.  Lift bezel away from Topper.  <b>*Ground Cable &amp; Power cable remains attached between Bezel &amp; Assembly – Take care not to strain or disconnect looms.</b>	 A perspective view of the GT4010 Topper assembly with the bezel removed. The bezel is shown as a separate grey frame. The internal green PCB is visible, and a red circle highlights the connection point between the bezel and the assembly. The power and ground cables are attached to the bottom of the assembly.

3.

Fit the artwork to the assembly by aligning the cut-outs of the artwork to the tabs of the metal frame.

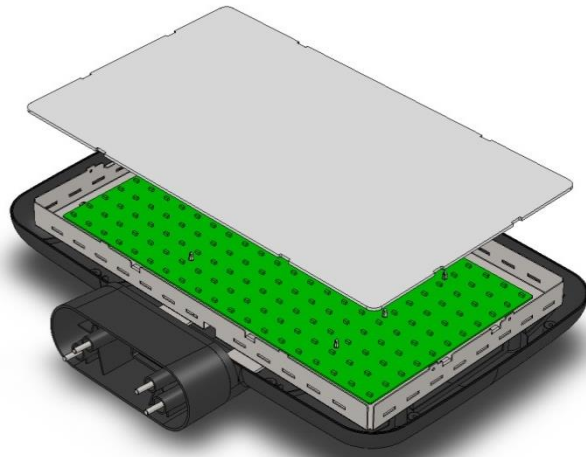

4.

Refit Bezel (Take care not to pinch or catch ground and power cables) and while holding all in place flip the assembly over.

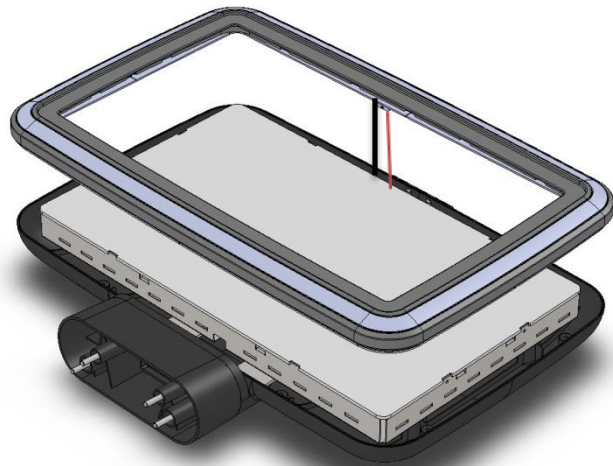

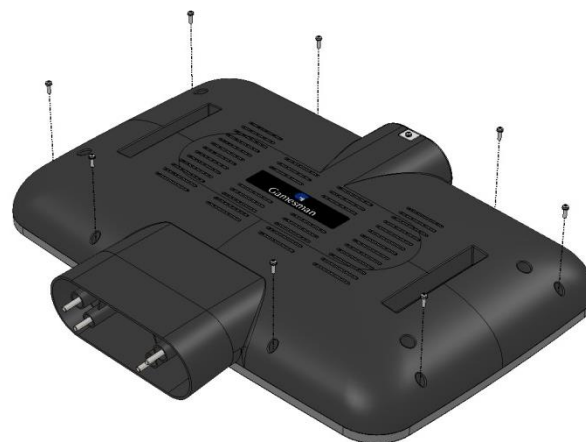

5.

Attach 8 screws ensuring edges are aligned all around



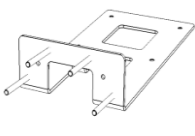
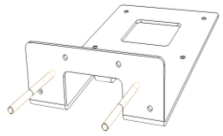

# Configurator/Specification Sheets

## GT4000

		<b>Spec Sheet :</b> <b>GT4000</b>			
Issue: 04 30.10.2017				<b>ENTER APPROPRIATE LETTER BELOW</b>	
<b>Supply Voltage</b>	A) 12v & 24v		B) 24v Only		
<b>LCD SCREEN</b>	S) Standard	H) High Brightness	X) Custom (1)		
<b>ON - BOARD MEMORY (Media Player)</b>	A) Yes		B) No		
<b>LCD CONNECTIVITY</b>	A) VGA	B) HDMI (1.2m Cable)	C) HDMI (7M Cable)		
	D) DVI		Z) N/A (Standard when using On-Board Memory)		
<b>Method of Periphery LED Sequence Selection</b>	M) Manual (Rotary Switch)	R) RS232	X) Custom (Specify Below)		
<b>LED Sequence</b>	A) Standard (Seq 2, RYW)		X) Custom (Specify Below)		
<b>Round Candle Adaptor Kit</b>	A) Yes		B) No		
<b>Towerlight Blanking Plate</b>	A) Yes		B) No		
<b>Bezel Colour Options</b>	A) Black		X) Custom (Specify Below)		
<b>Base Support Layout</b>					X) Custom (Please Specify)
	A) Standard		B) Alternate		
<b>Base Moulding</b>	A) Yes	Z) No	X) Custom (2)		
<b>Customer</b>					
<b>Customer Part Number:</b>					
<b>Specification Code:</b>			<b>GT4000</b>		
<i>For manual control of periphery Bezel illumination: ROTARY SWITCH PCBA (0927-G02151) Available Separately - Contact Sales Team</i>					
<b>Custom Requirements (X)</b>					
NOTES: (1) Please specify requirements for any custom LCD settings, including brightness/contrast specifications. (2) Supplied as standard with Flat Base. Contact our Sales team should you have any specific mounting requirements					
For Technical information, please visit our website <a href="http://www.gamesman.co.uk">www.gamesman.co.uk</a> If any of the above options are not applicable, please enter 'Z' Gamesman Ltd Crompton Fields, Crompton Way, Crawley, West Sussex, RH10 9QB Tel: +44 (0)1293 418888 Fax: +44 (0)1293 418880 Email: <a href="mailto:sales@gamesman.co.uk">sales@gamesman.co.uk</a>					

# GT4010

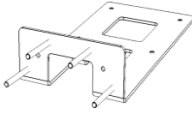
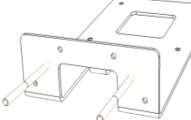
		<b>Spec Sheet :</b> <b>GT4010</b>			
Issue: 04.30.10.2017				<b>ENTER APPROPRIATE LETTER BELOW</b>	
<b>Supply Voltage</b>	A) 12v & 24v		B) 24v Only		
<b>Method of Periphery LED Sequence Selection</b>	M) Manual (Rotary Switch)	R) RS232	X) Custom (Specify Below)		
<b>LED Sequence</b>	A) Standard (Seq 2, RYW)		X) Custom (Specify Below)		
<b>Round Candle Adaptor Kit</b>	A) Yes		B) No		
<b>Towerlight Blanking Plate</b>	A) Yes		B) No		
<b>Bezel Colour Options</b>	A) Black		X) Custom (Specify Below)		
<b>Base Support Layout</b>	 A) Standard	 B) Alternate	X) Custom (Please Specify)		
<b>Base Moulding</b>	A) Yes	Z) No	X) Custom (1)		
<b>Customer</b>					
<b>Customer Part Number</b>					
<b>Specification Code:</b>		<b>GT4010</b>			
<i>For manual control of periphery Bezel illumination: ROTARY SWITCH PCBA (0927-G02151) Available Separately - Contact Sales Team</i>					
<b>Custom Requirements (X)</b>					
NOTES: (1) Supplied as standard with Flat Base. Contact our Sales team should you have any specific mounting requirements					
For Technical information, please visit our website <a href="http://www.gamesman.co.uk">www.gamesman.co.uk</a> If any of the above options are not applicable, please enter 'Z' Gamesman Ltd Crompton Fields, Crompton Way, Crawley, West Sussex, RH10 9QB Tel: +44 (0)1293 418888 Fax: +44 (0)1293 418880 Email: <a href="mailto:sales@gamesman.co.uk">sales@gamesman.co.uk</a>					

If you would like a combination not listed above or have any custom requirements, please contact Gamesman to discuss.

# **APPENDIX A; Standard LCD Specification**

# GT4000 LCD Topper AUO Panel Spec



Gamesman



# Product Specification

M185XTN01.2

AU OPTRONICS CORPORATION

( V ) Preliminary Specification

( ) Final Specification

<b>Module</b>	18.5" Color TFT-LCD
<b>Model Name</b>	M185XTN01.2

<b>Customer</b>	<b>Date</b>
_____	_____
<b>Approved by</b>	
_____	_____
<p>Note: This Specification is subject to change without notice.</p>	

<b>Approved by</b>	<b>Date</b>
<i>Chiyin Wu</i>	_____
<b>Prepared by</b>	
<i>Glenn Chan</i>	<u>2012/5/9</u>
<p>Desktop Display Business Group / AU Optronics corporation</p>	



Contents

**1.0 Handling Precautions ..... 4**

**2.0 General Description ..... 4**

    2.1 Display Characteristics ..... 5

    2.2 Optical Characteristics ..... 6

**3.0 Functional Block Diagram ..... 10**

**4.0 Absolute Maximum Ratings ..... 11**

    4.1 TFT LCD Module ..... 11

    4.2 Backlight Unit ..... 11

    4.3 Absolute Ratings of Environment ..... 11

**5.0 Electrical characteristics ..... 13**

    5.1 TFT LCD Module ..... 13

**5.1.1 Power Specification ..... 13**

**5.1.2 Signal Electrical Characteristics ..... 14**

    5.2 Backlight Unit ..... 16

**6.0 Signal Characteristic ..... 17**

    6.1 Pixel Format Image ..... 17

    6.2 The input data format ..... 17

    6.3 Signal Description ..... 18

    6.4 Timing Characteristics ..... 20

    6.5 Timing diagram ..... 21

    6.6 Power ON/OFF Sequence ..... 22

**7.0 Connector & Pin Assignment ..... 23**

    7.1 TFT LCD Module ..... 23

**7.1.1 Pin Assignment ..... 23**

    7.2 LED Connector on Backlight Unit ..... 24

**7.2.1 LED Pin assignment ..... 24**

**7.2.2 LED Connector dimension ..... 25**

**7.2.3 LED Mating housing dimension ..... 25**

**8.0 Reliability Test ..... 26**

**9.0 Shipping Label ..... 27**

**10.0 Mechanical Characteristics ..... 28**

**11. Packing Specification ..... 30**

## Record of Revision

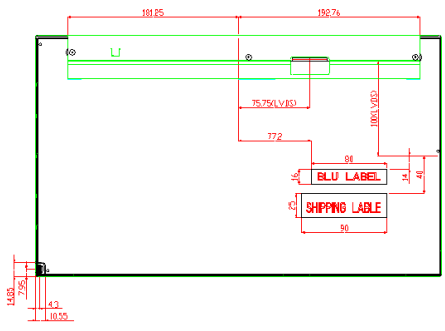
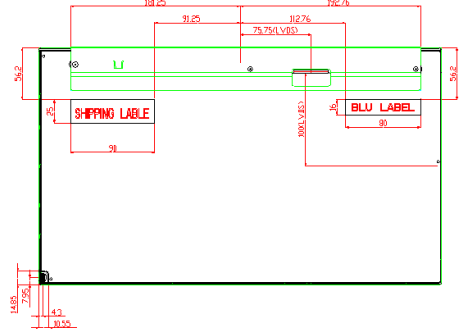
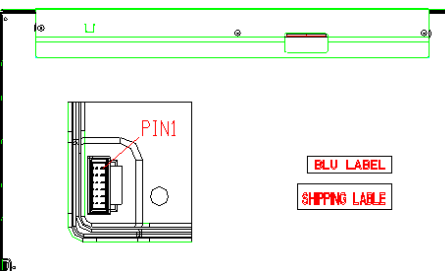
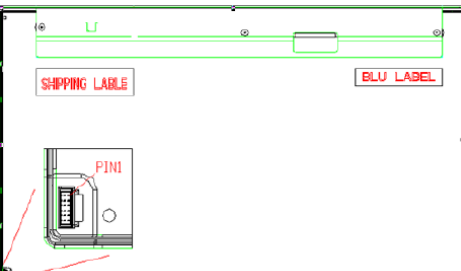
Version and Date	Page	Old description	New Description	Remark
0.1 2012/05/09		Preliminary Version		
0.2 2012/6/18	29	Update label positions. 		
	11	Logic/LCD Drive Voltage VDD: +5.5V	Logic/LCD Drive Voltage VDD: +6.0V	
	13	5.1.1 Power specification Irush Max. :2A	5.1.1 Power specification Irush Max. : TBD	
	24			

## 1.0 Handling Precautions

- 1) Since front polarizer is easily damaged, pay attention not to scratch it.
- 2) Be sure to turn off power supply when inserting or disconnecting from input connector.
- 3) Wipe off water drop immediately. Long contact with water may cause discoloration or spots.
- 4) When the panel surface is soiled, wipe it with absorbent cotton or other soft cloth.
- 5) Since the panel is made of glass, it may break or crack if dropped or bumped on hard surface.
- 6) Since CMOS LSI is used in this module, take care of static electricity and insure human earth when handling.
- 7) Do not open or modify the Module Assembly.
- 8) Do not press the reflector sheet at the back of the module to any directions.
- 9) In case if a Module has to be put back into the packing container slot after once it was taken out from the container, do not press the center of the LED lightbar edge. Instead, press at the far ends of the LED light bar edge softly. Otherwise the TFT Module may be damaged.
- 10) At the insertion or removal of the Signal Interface Connector, be sure not to rotate nor tilt the Interface Connector of the TFT Module.
- 11) After installation of the TFT Module into an enclosure, do not twist nor bend the TFT Module even momentary. At designing the enclosure, it should be taken into consideration that no bending/twisting forces are applied to the TFT Module from outside. Otherwise the TFT Module may be damaged.
- 12) Small amount of materials having no flammability grade is used in the LCD module. The LCD module should be supplied by power complied with requirements of Limited Power Source (IEC60950 or UL1950), or be applied exemption.
- 13) Please avoid touching COF contact while handling or fitting the TFT module into your system.
- 14) When storing modules as spares for a long time, the following precaution is necessary:  
Store them in a dark place. Do not expose the module to sunlight or fluorescent light. Keep the temperature between 5°C and 35°C at normal humidity.

## 2.0 General Description

This specification applies to the 18.5 inch-wide Color a-Si TFT-LCD Module M185XW01. The display supports the WXGA - 1366(H) x 768(V) screen format and 16.7M colors (RGB 6-bits + Hi-FRC data). All input signals are 1-channel LVDS interface and this module doesn't contain an inverter board for backlight.

## 2.1 Display Characteristics

The following items are characteristics summary on the table under 25°C condition:

ITEMS	Unit	SPECIFICATIONS
Screen Diagonal	[mm]	470.1(18.51")
Active Area	[mm]	409.8 (H) x 230.4 (V)
Pixels H x V		1366(x3) x 768
Pixel Pitch	[um]	300 (per one triad) x 300
Pixel Arrangement		R.G.B. Vertical Stripe
Display Mode		TN Mode, Normally White
White Luminance ( Center )	[cd/m <sup>2</sup> ]	250 cd/m <sup>2</sup> (Typ.)
Contrast Ratio		1000 (Typ.)
Optical Response Time	[msec]	5ms (Typ., on/off)
Nominal Input Voltage VDD	[Volt]	+5.0 V (Typ)
Power Consumption (VDD line + LED line)	[Watt]	VDD line: PDD (typ)= 1.75W, All black pattern at 60Hz LED line : PBLU (typ) = 7.2W Total : 8.95W
Weight	[Grams]	1290 (Typ)
Physical Size	[mm]	430.4 (W) x 254.6 (H) Typ. x 9.9 (D) Typ
Interface		One channel LVDS
Support Color		16.7M colors (RGB 6-bit + Hi_FRC )
Surface Treatment		Anti-Glare, 3H
Temperature Range		
Operating	[°C]	0 to +50
Storage (Shipping)	[°C]	-20 to +60
TCO6.0 Compliance		Yes
Energy Star 6.0 Compliance		Yes

## 2.2 Optical Characteristics

The optical characteristics are measured under stable conditions at 25°C :

Item	Unit	Conditions	Min.	Typ.	Max.	Note
Viewing Angle	[degree]	Horizontal (Right) CR = 10 (Left)	75 75	85 85	- -	<b>2</b>
		Vertical (Up) CR = 10 (Down)	70 70	80 80	- -	
Contrast ratio		Normal Direction	600	1000	-	<b>3</b>
Response Time	[msec]	Raising Time ( $T_{rR}$ )	-	3.6	-	<b>4</b>
		Falling Time ( $T_{rF}$ )	-	1.4	-	
		Raising + Falling	-	5	-	
Color / Chromaticity Coordinates (CIE)		Red x	TBD	TBD	TBD	<b>5</b>
		Red y	TBD	TBD	TBD	
		Green x	TBD	TBD	TBD	
		Green y	TBD	TBD	TBD	
		Blue x	TBD	TBD	TBD	
		Blue y	TBD	TBD	TBD	
Color Coordinates (CIE) White		White x	0.283	0.313	0.343	
		White y	0.299	0.329	0.359	
Central Luminance	[ $cd/m^2$ ]		200	250	-	<b>6</b>
Luminance Uniformity	[%]		75	80	-	<b>7</b>
Crosstalk (in 60Hz)	[%]				1.5	<b>8</b>
Flicker	dB				-20	<b>9</b>

## Note 1: Measurement method

The LCD module should be stabilized at given temperature for 30 minutes to avoid abrupt temperature change during measuring (at surface 35°C). In order to stabilize the luminance, the measurement should be executed after lighting Backlight for 30 minutes in a stable, windless and dark room.

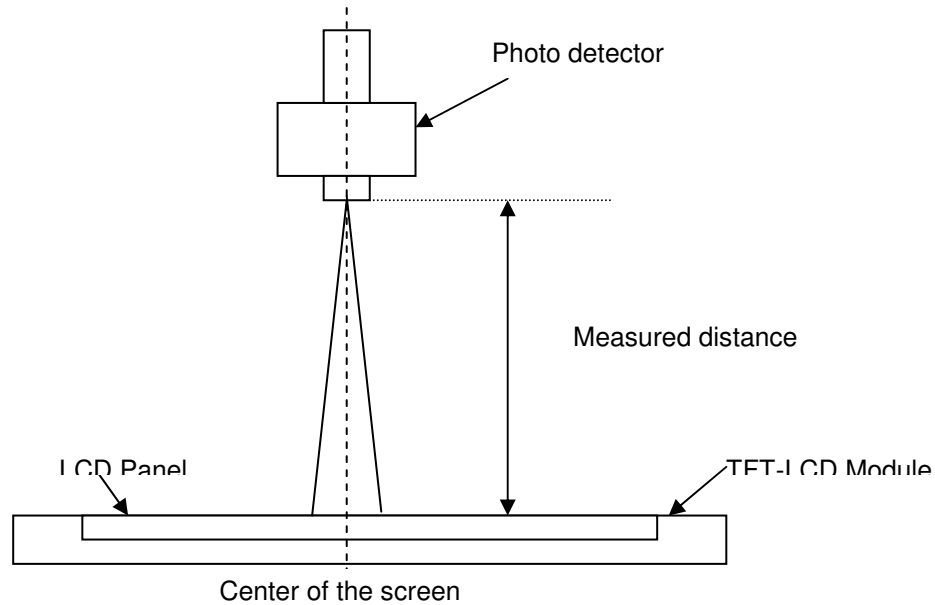

## Note 2: Definition of viewing angle measured by ELDIM (EZContrast 88)

Viewing angle is the measurement of contrast ratio  $\geq 10$ , at the screen center, over a 180° horizontal and 180° vertical range (off-normal viewing angles). The 180° viewing angle range is broken down as follows; 90° ( $\theta$ ) horizontal left and right and 90° ( $\phi$ ) vertical, high (up) and low (down). The measurement direction is typically perpendicular to the display surface with the screen rotated about its center to develop the desired measurement viewing angle.

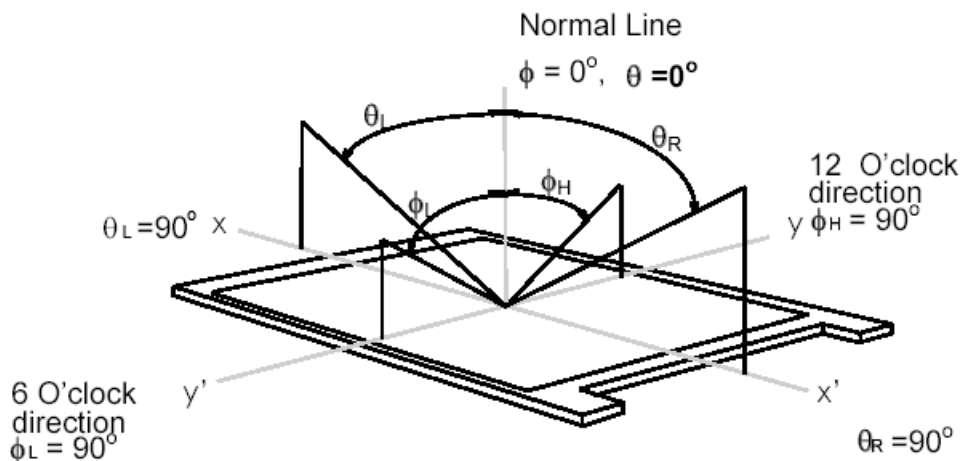

**Note 3: Contrast ratio is** measured by TOPCON SR-3

**Note 4: Definition of Response time** measured by Westar TRD-100A

The output signals of photo detector are measured when the input signals are changed from “Full Black” to “Full White” (rising time,  $T_{rR}$ ), and from “Full White” to “Full Black” (falling time,  $T_{rF}$ ), respectively. The response time is interval between the 10% and 90% (1 frame at 60 Hz) of amplitudes.

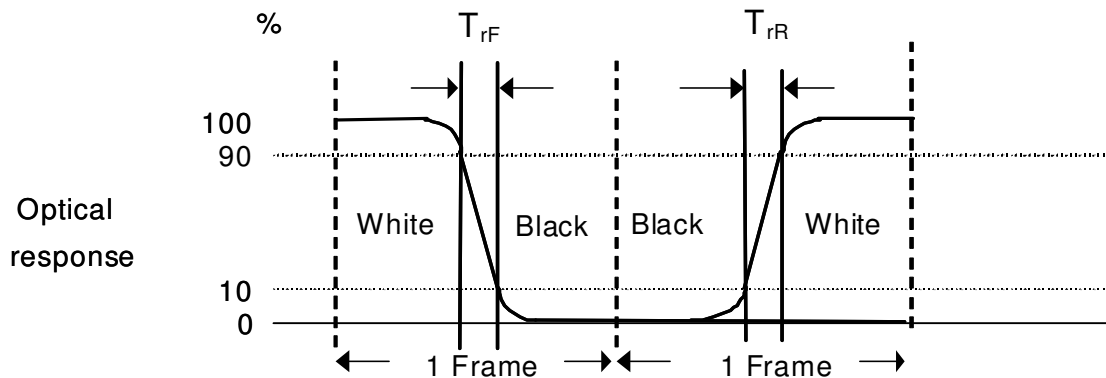

$T_{rR} + T_{rF} = 5$  msec (typ.).

**Note 5: Color chromaticity and coordinates (CIE)** is measured by TOPCON SR-3

**Note 6: Central luminance is** measured by TOPCON SR-3

**Note 7: Luminance uniformity of these 9 points is defined as below and** measured by TOPCON SR-3

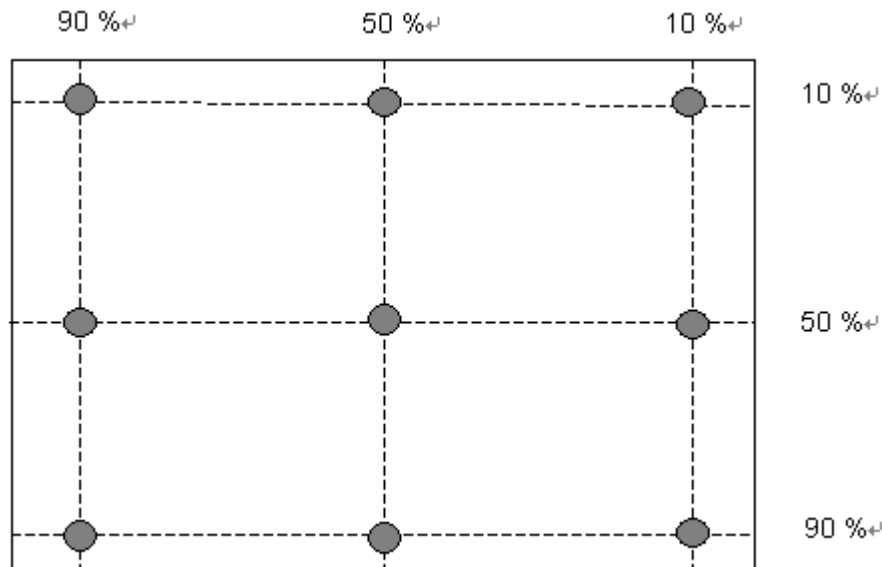

$$\text{Uniformity} = \frac{\text{Minimum Luminance in 9 points (1-9)}}{\text{Maximum Luminance in 9 Points (1-9)}}$$

**Note 8: Crosstalk is defined as below and** measured by TOPCON SR-3

$$CT = | YB - YA | / YA \times 100 (\%)$$

Where

YA = Luminance of measured location without gray level 0 pattern (cd/m<sup>2</sup>)

YB = Luminance of measured location with gray level 0 pattern (cd/m<sup>2</sup>)

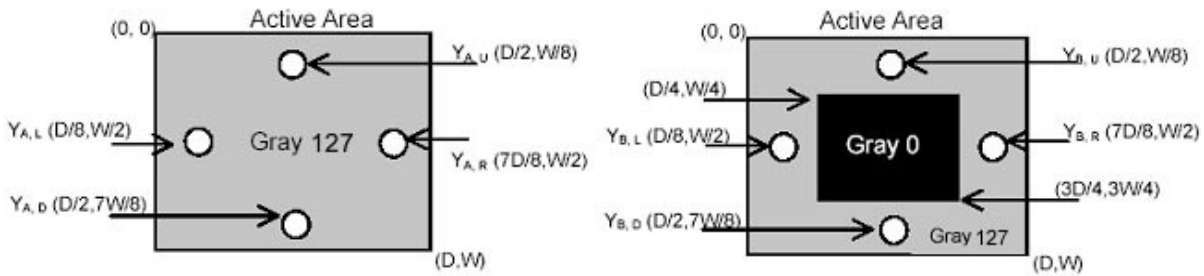

**Note 9: Test Pattern: Subchecker Pattern** measured by TOPCON SR-3

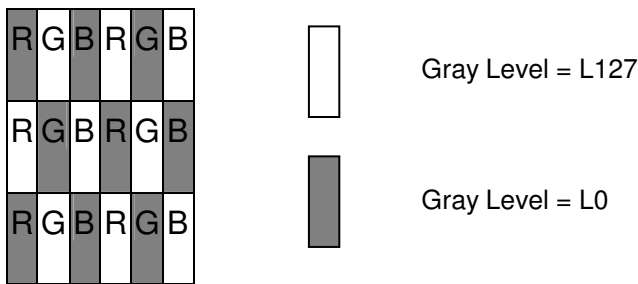

Method: Record dBV & DC value with TRD-100

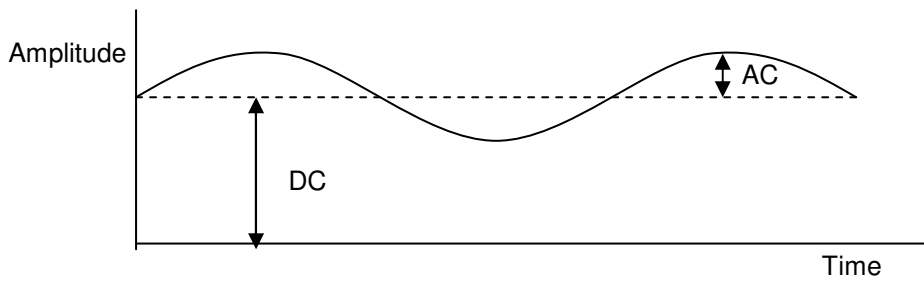

$$\text{Flicker (dB)} = 20 \log \frac{\text{AC Level (at 30 Hz)}}{\text{DC Level}}$$



### 3.0 Functional Block Diagram

The following diagram shows the functional block of the 18.5 inch Color TFT-LCD Module:

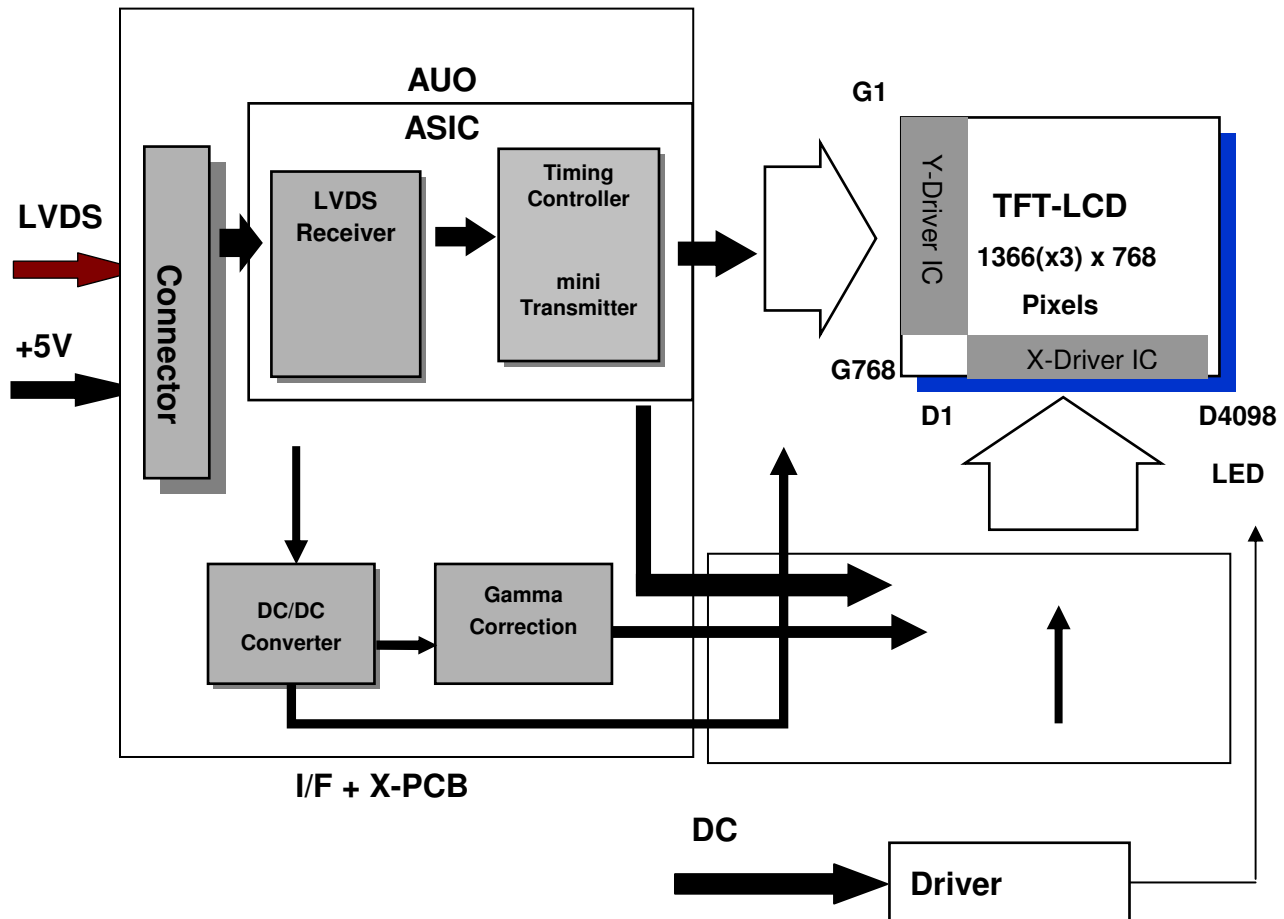

#### I/F PCB Interface:

MSCKT2407P30HB (STM) / AL230F-A0G1D-P (P-TWO)

#### Mating Type:

FI-X30HL(JAE) (Locked Type)

FI-X30H (JAE)(Unlocked Type)

## 4.0 Absolute Maximum Ratings

Absolute maximum ratings of the module are as following:

### 4.1 TFT LCD Module

Item	Symbol	Min	Max	Unit	Conditions
Logic/LCD Drive Voltage	VDD	0	+6.0	[Volt]	<b>Note 1,2</b>

### 4.2 Backlight Unit

Item	Symbol	Min	Max	Unit	Conditions
LED Forward Current	IRLED1	0	90	[mA]	<b>Note 1,2,5</b> 100% duty
	IRLED2				
	IRLED3				
	IRLED4				
LED Pulse Forward Current	IPLED1	-	150	[mA]	<b>Note 1,2,5</b> 10% duty @100Hz
	IPLED2				
	IPLED3				
	IPLED4				
LED forward Voltage variation (per string variation)	$\Delta V_f$	-	3.4	[Volt]	<b>Note 1,2</b>

### 4.3 Absolute Ratings of Environment

Item	Symbol	Min.	Max.	Unit	Conditions
Operating Temperature	TOP	0	+50	[°C]	<b>Note 3</b>
Glass surface temperature (operation)	TGS	0	+65	[°C]	<b>Note 3, Note 4</b>
Operation Humidity	HOP	5	90	[%RH]	<b>Note 3</b>
Storage Temperature	TST	-20	+60	[°C]	
Storage Humidity	HST	5	90	[%RH]	

**Note 1:** With in Ta (25°C)

**Note 2:** Permanent damage to the device may occur if exceeding maximum values

**Note 3:** Temperature and relative humidity range are shown as the below figure.

1. 90% RH Max ( Ta  $\leq$  39°C )
2. Max wet-bulb temperature at 39°C or less. ( Ta  $\leq$  39°C )
3. No condensation

**Note 4:** Function Judged only

**Note 5:** IRLED1,2,3,4 and IPLED1,2,3,4 define as per strings LED current.

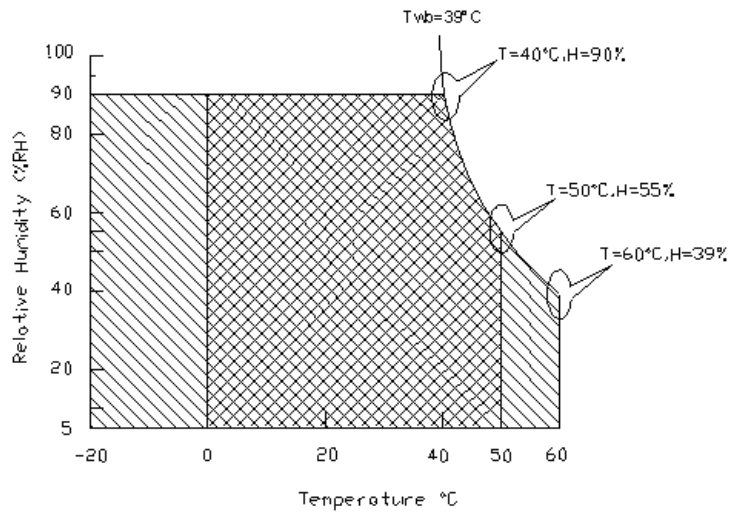

Operating Range



Storage Range

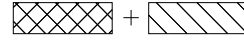

## 5.0 Electrical characteristics

### 5.1 TFT LCD Module

#### 5.1.1 Power Specification

Input power specifications are as following:

Symbol	Parameter	Min	Typ	Max	Unit	Conditions
VDD	Logic/LCD Drive Voltage	4.5	5.0	6	[Volt]	+/-10%
IDD	Input Current	-	0.35	0.42	[A]	VDD= 5.0V, All Black Pattern At 60Hz,
		-	0.42	0.5		VDD= 5.0V, All Black Pattern At 75Hz
PDD	VDD Power	-	1.75	2.1	[Watt]	VDD= 5.0V, All Black Pattern At 60Hz
		-	2.1	2.5		VDD= 5.0V, All Black Pattern At 75Hz
IRush	Inrush Current	-	-	TBD	[A]	Note 1
VDDrp	Allowable Logic/LCD Drive Ripple Voltage	-	-	350	[mV] p-p	VDD= 5.0V, All Black Pattern At 75Hz

**Note 1:** Measurement conditions:

The duration of rising time of power input is 470us.

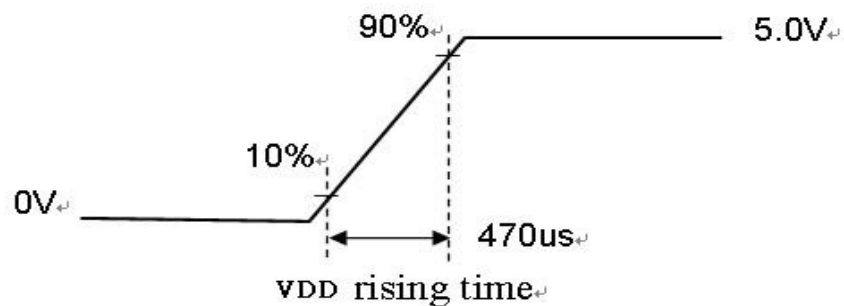
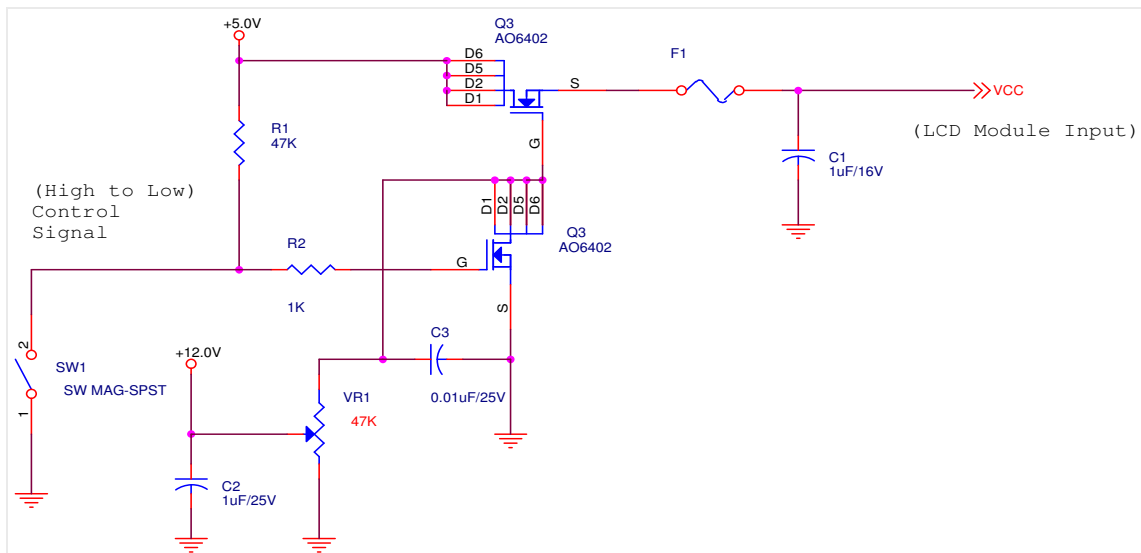

## 5.1.2 Signal Electrical Characteristics

Input signals shall be low or Hi-Z state when VDD is off. Please refer to specifications of SN75LVDS82DGG (Texas Instruments) in detail.

### 1. DC Characteristics of each signal are as following:

Symbol	Parameter	Min	Typ	Max	Units	Condition
V <sub>TH</sub>	Differential Input High Threshold	-	-	+100	[mV]	V <sub>CM</sub> = 1.2V <b>Note 1</b>
V <sub>TL</sub>	Differential Input Low Threshold	-100	-	-	[mV]	V <sub>CM</sub> = 1.2V <b>Note 1</b>
V <sub>ID</sub>	Input Differential Voltage	100	-	600	[mV]	<b>Note 1</b>
V <sub>CM</sub>	Differential Input Common Mode Voltage	+1.0	+1.2	+1.5	[V]	V <sub>TH</sub> -V <sub>TL</sub> = 200mV (max) <b>Note 1</b>

**Note 1:** LVDS Signal Waveform

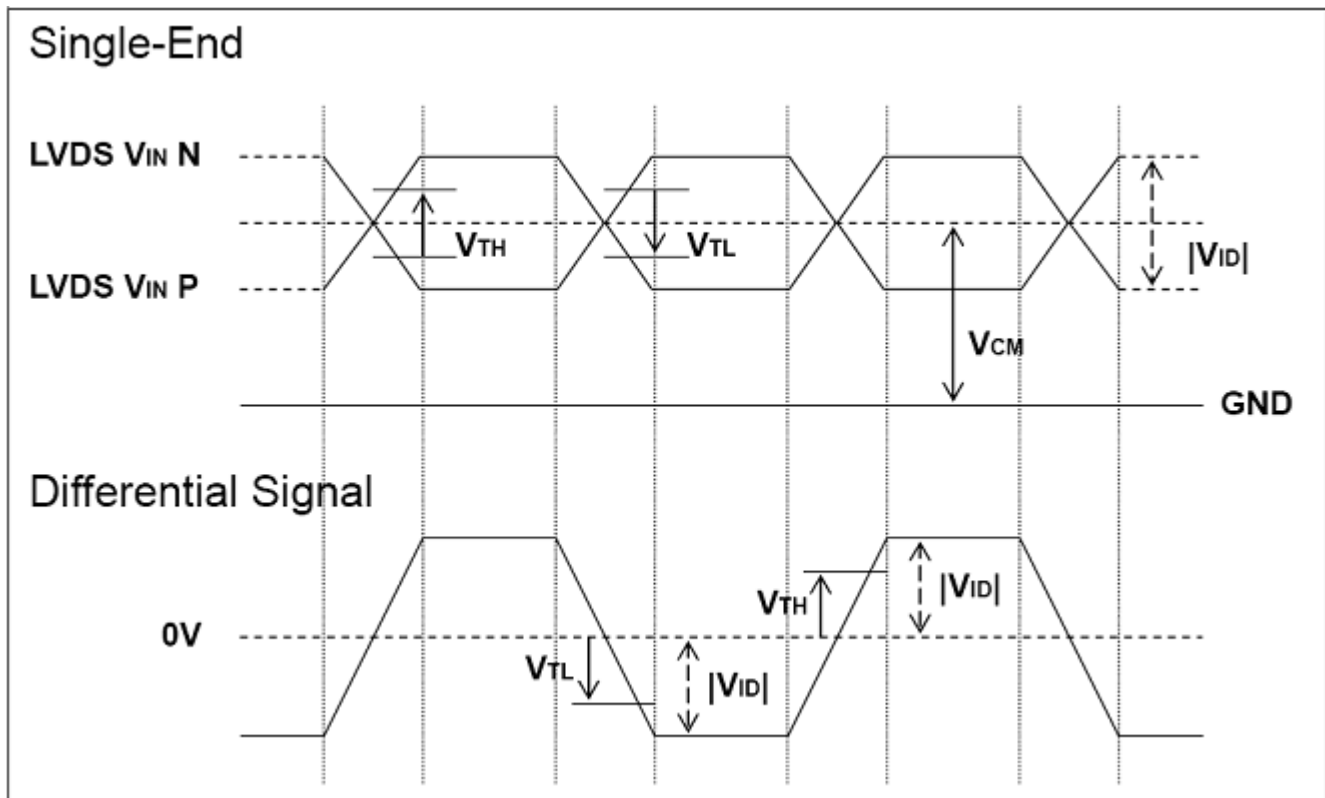

## 2. AC Characteristics

Description	Symbol	Min	Max	Unit	Note
Maximum deviation of input clock frequency during SSC	$F_{DEV}$	-	$\pm 3$	%	
Maximum modulation frequency of input clock during SSC	$F_{MOD}$	-	200	KHz	

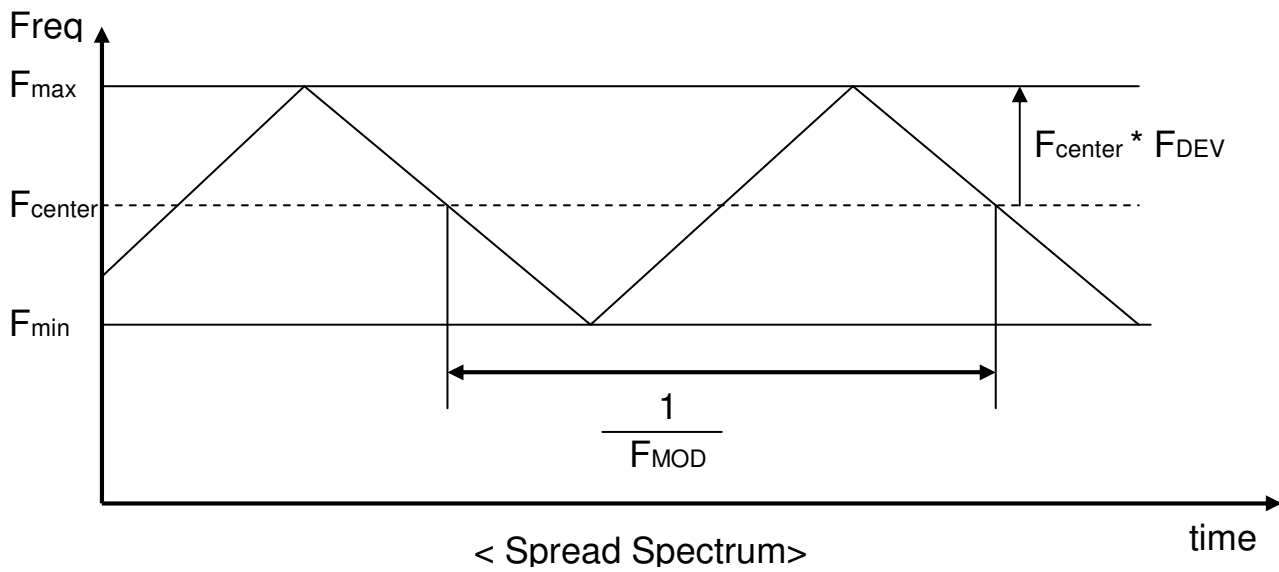

## 5.2 Backlight Unit

Parameter guideline for LED driving is under stable conditions at 25°C (Room Temperature):

Symbol	Description	Min.	Typ.	Max.	Unit	Note
IRLED1	LED Operation Current	67	70	73	[mA]	<b>Note 1</b>
IRLED2						
IRLED3						
IRLED4						
VLED	Light Bar Operation Voltage	24	25.6	27.2	[Volt]	<b>Note 2</b>
PBLU	BLU Power Consumption	6.4	7.2	7.9	[Watt]	<b>Note 3</b>
LTLED	LED Life Time (Typical)	30,000	-	-	[Hour]	<b>Note 4</b>

Each module consists of 32 pcs LED ( 4 strings x 8 pcs / string )

Note 1 : The specified current is 100% duty of LED chip input current, IRLED1,2,3,4 define as per strings LED current.

Note 2 : The value showed in the table is one light bar's operation voltage.

Note 3 :  $PBLU = VLED * ( IRLED1 + IRLED2 + IRLED3 + IRLED4 )$

Note 4: Definition of life time: Brightness becomes to 50% of its original value. The minimum life time of LED unit is on the condition of IRLED = 70mA and 25±2°C (Room Temperature).

## 6.0 Signal Characteristic

### 6.1 Pixel Format Image

Following figure shows the relationship of the input signals and LCD pixel format.

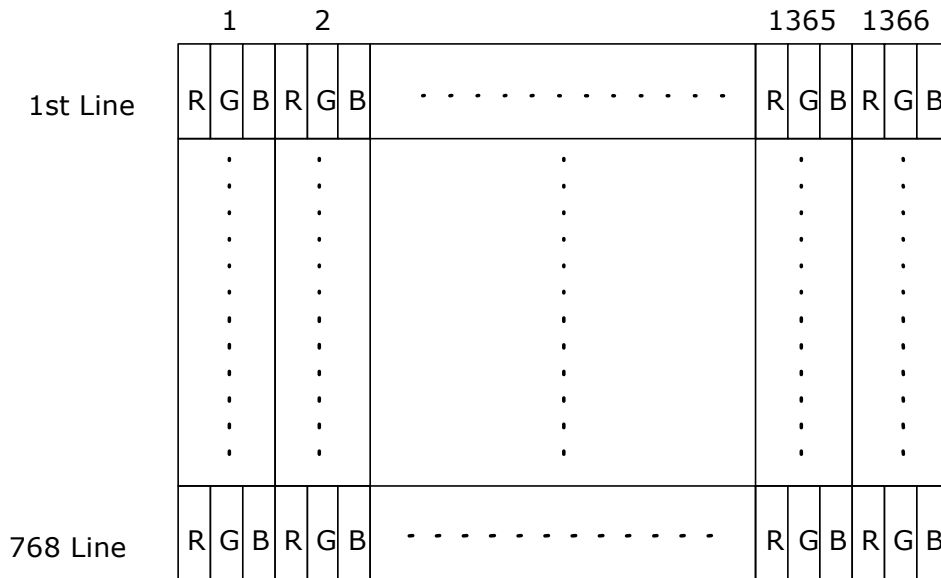

### 6.2 The input data format

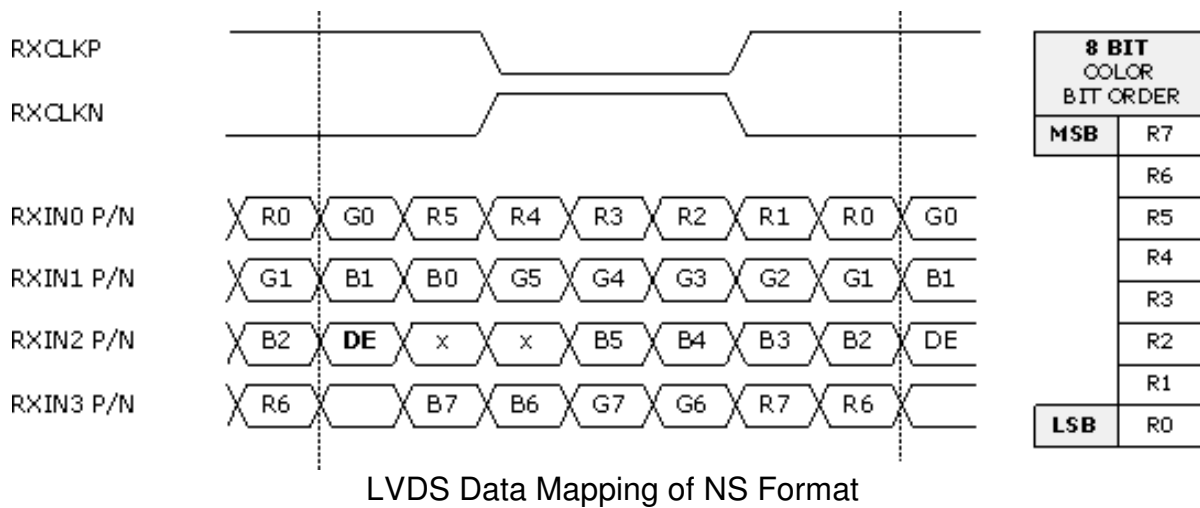

Note1: Normally, DE, VS, HS on EVEN channel are not used.

Note2: 8-bits signal input.



## 6.3 Signal Description

PIN #	SIGNAL NAME	DESCRIPTION
1	NC	No contact (For AUO internal use)
2	NC	No contact (For AUO internal use)
3	NC	No contact (For AUO internal use)
4	GND	Power Ground
5	RXIN0-	Negative LVDS differential data input (0)
6	RXIN0+	Positive LVDS differential data input (0)
7	GND	Power Ground
8	RXIN1-	Negative LVDS differential data input (1)
9	RXIN1+	Positive LVDS differential data input (1)
10	GND	Power Ground
11	RXIN2-	Negative LVDS differential data input (2)
12	RXIN2+	Positive LVDS differential data input (2)
13	GND	Power Ground
14	RXCLKIN-	Negative LVDS differential clock input (clock)
15	RXCLKIN+	Positive LVDS differential data input (clock)
16	GND	Power Ground
17	RXIN3-	Negative LVDS differential data input (3)
18	RXIN3+	Positive LVDS differential data input (3)
19	GND	Power Ground
20	NC	No contact (For AUO internal use)
21	NC	No contact (For AUO internal use)
22	NC	No contact (For AUO internal use)
23	GND	Power Ground
24	GND	Power Ground
25	GND	Power Ground
26	VCC	+5V power supply
27	VCC	+5V power supply
28	VCC	+5V power supply
29	VCC	+5V power supply
30	VCC	+5V power supply

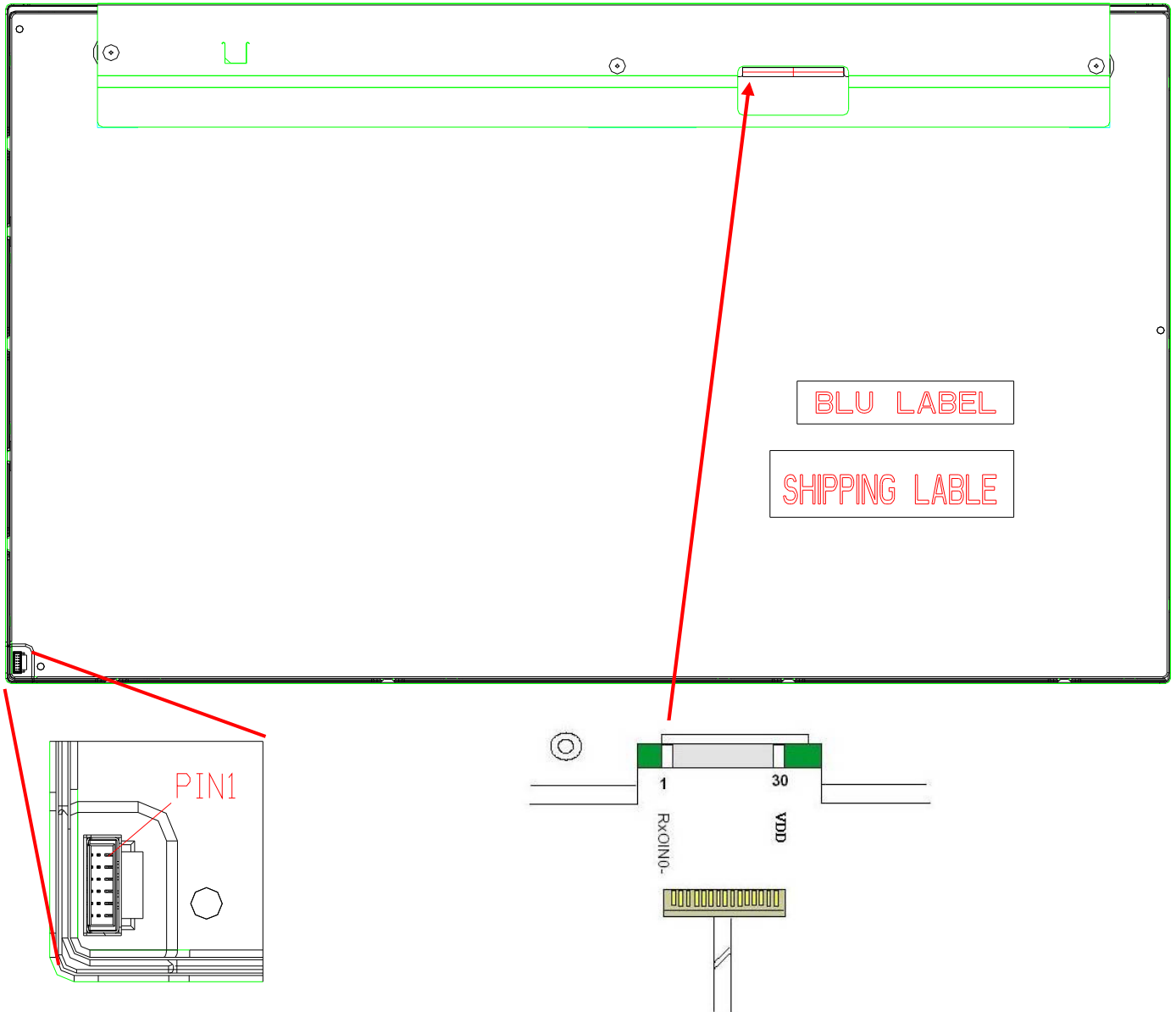

## 6.4 Timing Characteristics

Basically, interface timing described here is not actual input timing of LCD module but close to output timing of SN75LVDS82DGG (Texas Instruments) or equivalent.

Signal	Item	Symbol	Min	Typ	Max	Unit
<b>V-section</b>	Period	Tv	776	808	1023	Th
	Active	Tdisp(v)	768	768	768	Th
	Blanking	Tblk(v)	8	40	255	Th
<b>H-section</b>	Period	Th	1416	1606	2047	Tclk
	Active	Tdisp(h)	1366	1366	1366	Tclk
	Blanking	Tblk(h)	50	240	681	Tclk
<b>Clock</b>	Period	Tclk	-	12.8	-	ns
	Frequency	Freq	55	78	90	MHz
<b>Frame Rate</b>	Frame Rate	F	50	60	75	Hz

**Note1** : DE mode only

**Note2** : Clock Frequency 90MHz(Max.)= 1416(H)\*847(V)\*75Hz

## 6.5 Timing diagram

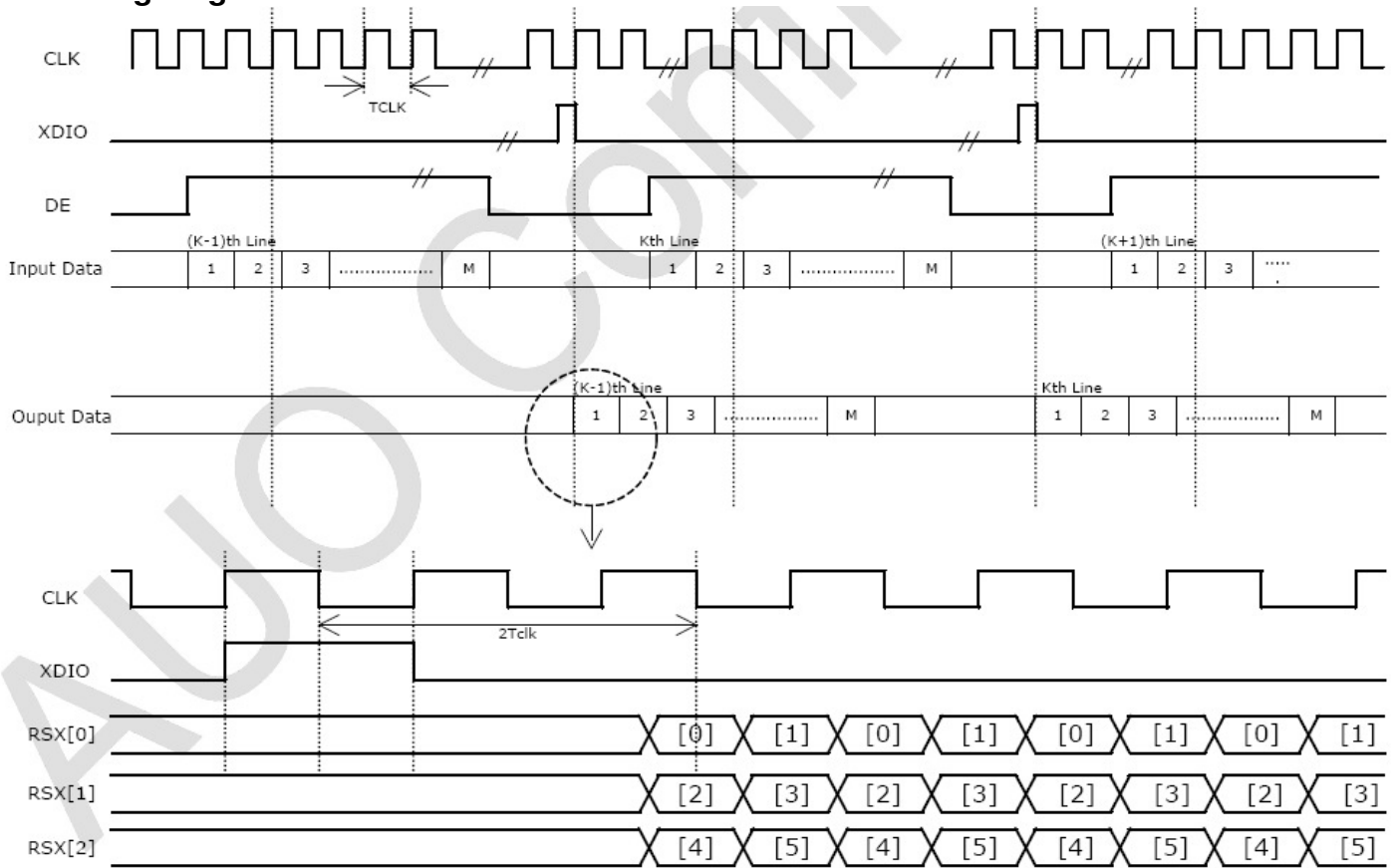

## 6.6 Power ON/OFF Sequence

VDD power and lamp on/off sequence are as follows. Interface signals are also shown in the chart. Signals from any system shall be Hi-Z state or low level when VDD is off.

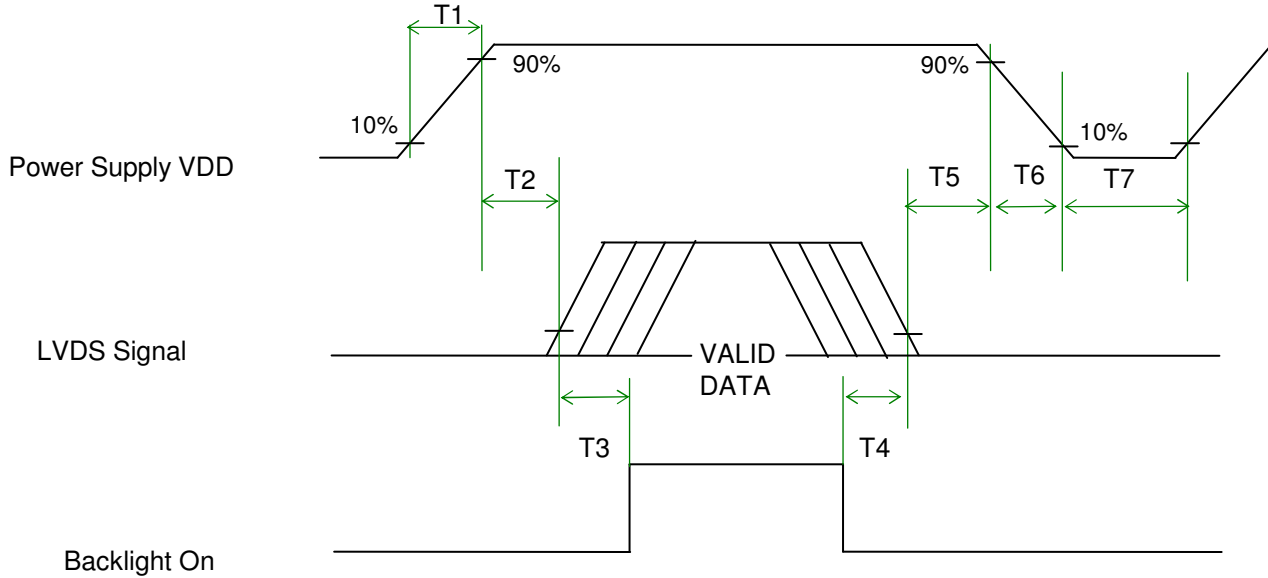

**Power Sequence Timing**

Parameter	Value			Unit
	Min.	Typ.	Max.	
T1	0.5	-	10	[ms]
T2	0	-	50	[ms]
T3	500	-	-	[ms]
T4	100	-	-	[ms]
T5	0	-	50	[ms] <i>Note1,2</i>
T6	5	-	100	[ms] <i>Note1,2</i>
T7	1000	-	-	[ms]

**Note1** : Recommend setting T5 = 0ms to avoid electronic noise when VDD is off.

**Note2** : During T5 and T6 period , please keep the level of input LVDS signals with Hi-Z state.

## 7.0 Connector & Pin Assignment

Physical interface is described as for the connector on module. These connectors are capable of accommodating the following signals and will be following components.

### 7.1 TFT LCD Module

Connector Name / Designation	Interface Connector / Interface card
Manufacturer	STM or P-TWO
Type Part Number	MSCKT2407P30HB (STM) / AL230F-A0G1D-P (P-TWO)
Mating Housing Part Number	FI-X30HL(JAE) (Locked Type) FI-X30H (JAE)(Unlocked Type)

#### 7.1.1 Pin Assignment

Pin#	Signal Name	Pin#	Signal Name
1	NC	2	NC
3	NC	4	GND
5	RXIN0-	6	RXIN0+
7	GND	8	RXIN1-
9	RXIN1+	10	GND
11	RXIN2-	12	RXIN2+
13	GND	14	RXCLKIN-
15	RXCLKIN+	16	GND
17	RXIN3-	18	RXIN3+
19	GND	20	NC
21	NC	22	NC
23	GND	24	GND
25	GND	26	VCC
27	VCC	28	VCC
29	VCC	30	VCC

## 7.2 LED Connector on Backlight Unit.

This connector is mounted on LED light-bar.

Connector Name / Designation	Light Bar Connector
Manufacturer	ENTERY (E&T) Corporation
Mating Type Part Number	<b>3707K-Q06N-01R</b> (Wire harness)

### 7.2.1 LED Pin assignment

Pin#	Signal Name
1	IRLED1 (current out)
2	IRLED2 (current out)
3	VLED (voltage in)
4	VLED (voltage in)
5	IRLED3 (current out)
6	IRLED4 (current out)

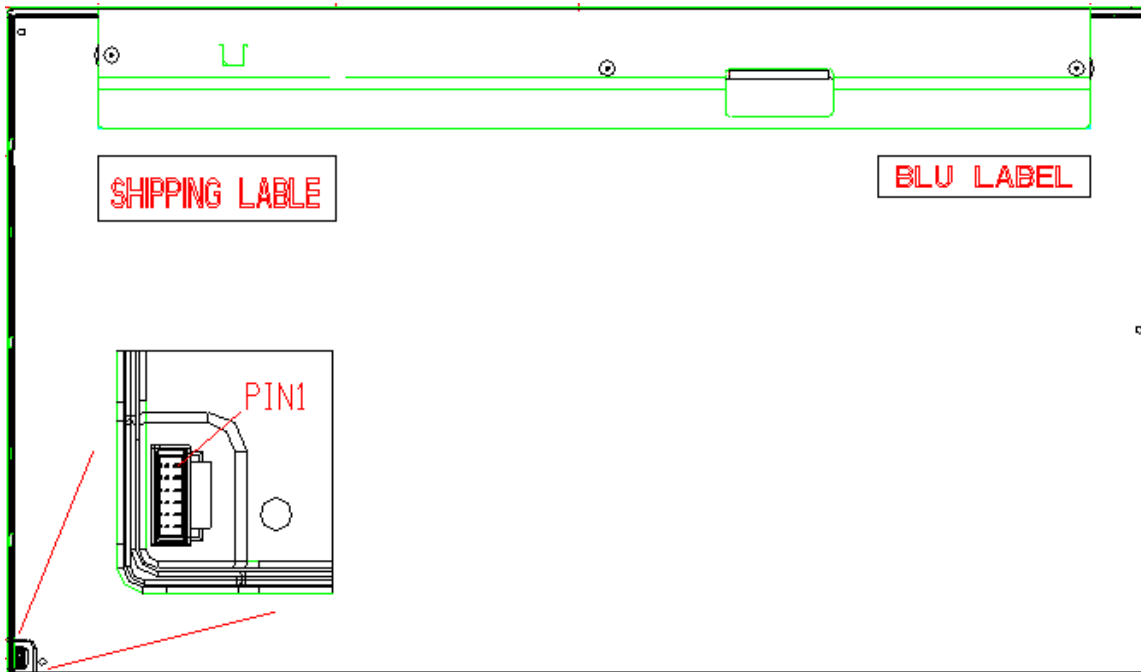

## 7.2.2 LED Connector dimension

$H \times V \times D = 13.9 \times 3.00 \times 4.25$ , Pitch = 1.0 (unit = mm)

$H \times V \times D = 13.9 \times 3.00 \times 4.25$ , Pitch = 1.0 (unit = mm)

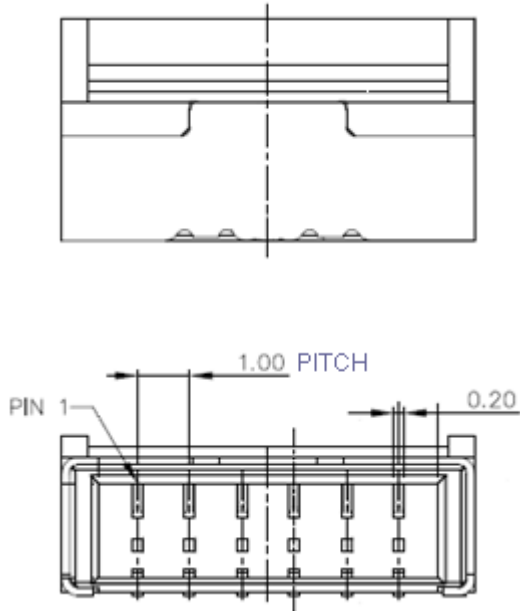

## 7.2.3 LED Mating housing dimension

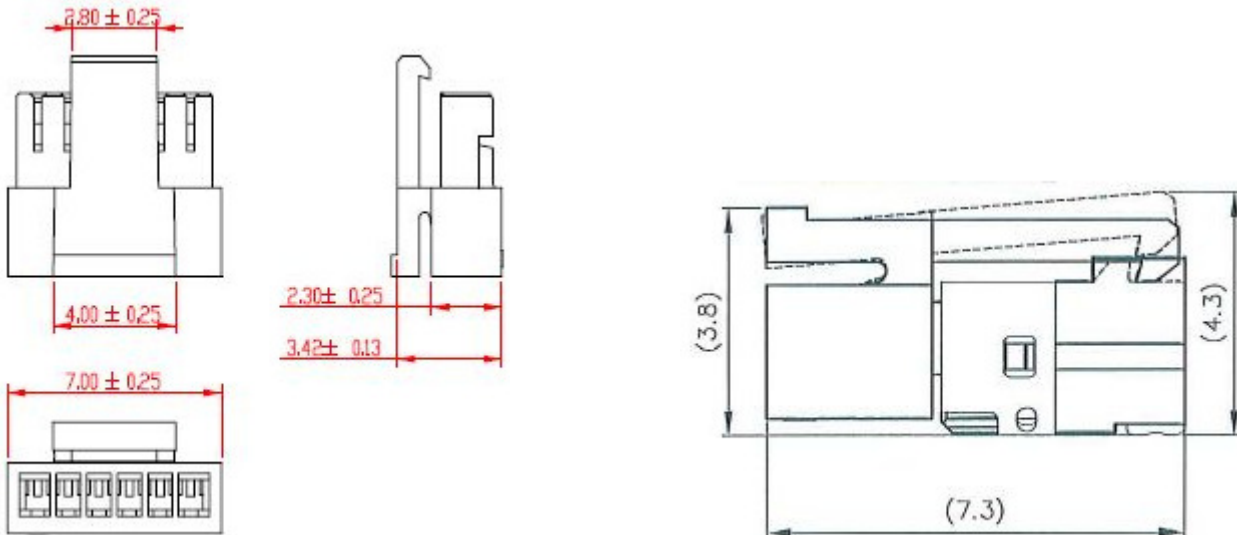



## 8.0 Reliability Test

Environment test conditions are listed as following table.

Items	Required Condition	Note
Temperature Humidity Bias (THB)	Ta= 50°C , 80%RH, 300hours	
High Temperature Operation (HTO)	Ta= 50°C , 50%RH, 300hours	
Low Temperature Operation (LTO)	Ta= 0°C , 300hours	
High Temperature Storage (HTS)	Ta= 60°C , 300hours	
Low Temperature Storage (LTS)	Ta= -20°C , 300hours	
Vibration Test (Non-operation)	Acceleration: 1.5 Grms Wave: Random Frequency: 10 - 200 Hz Duration: 30 Minutes each Axis (X, Y, Z)	
Shock Test (Non-operation)	Acceleration: 50 G Wave: Half-sine Active Time: 20 ms Direction: ±X, ±Y, ±Z (one time for each Axis)	
Drop Test	Height: 46 cm, package test	
Thermal Shock Test (TST)	-20°C/30min, 60°C/30min, 100 cycles	<b>1</b>
On/Off Test	On/10sec, Off/10sec, 30,000 cycles	
ESD (Electro Static Discharge)	Contact Discharge: ± 15KV, 150pF(330Ω ) 1sec, 15 points, 25 times/ point.	<b>2</b>
	Air Discharge: ± 15KV, 150pF(330Ω ) 1sec 15 points, 25 times/ point.	
Altitude Test	Operation:15,000 ft Non-Operation:40,000 ft	

**Note 1:** The TFT-LCD module will not sustain damage after being subjected to 100 cycles of rapid temperature change. A cycle of rapid temperature change consists of varying the temperature from -20°C to 60°C, and back again. Power is not applied during the test. After temperature cycling, the unit is placed in normal room ambient for at least 4 hours before power on.

**Note 2:** EN61000-4-2, ESD class B:

Certain performance degradation allowed

No data lost

Self-recoverable

No hardware failures.

## 9.0 Shipping Label

The label is on the panel as shown below:

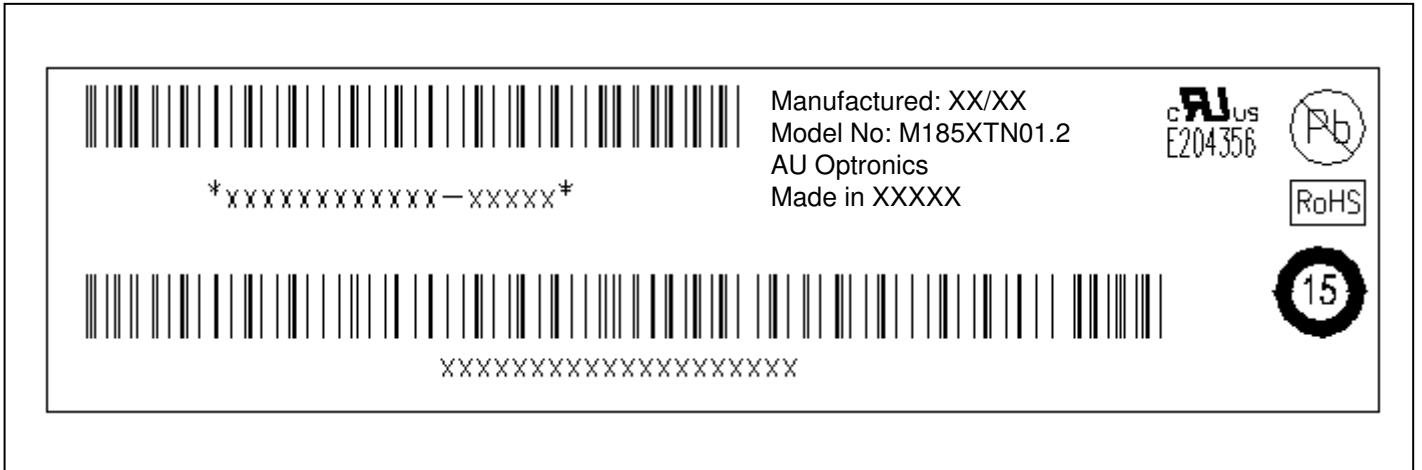

**Note 1:** For Pb Free products, AUO will add  for identification.

**Note 2:** For RoHS compatible products, AUO will add  for identification.

**Note 3:** For China RoHS compatible products, AUO will add  for identification.

**Note 4:** The Green Mark will be presented only when the green documents have been ready by AUO Internal Green Team.

## 10.0 Mechanical Characteristics

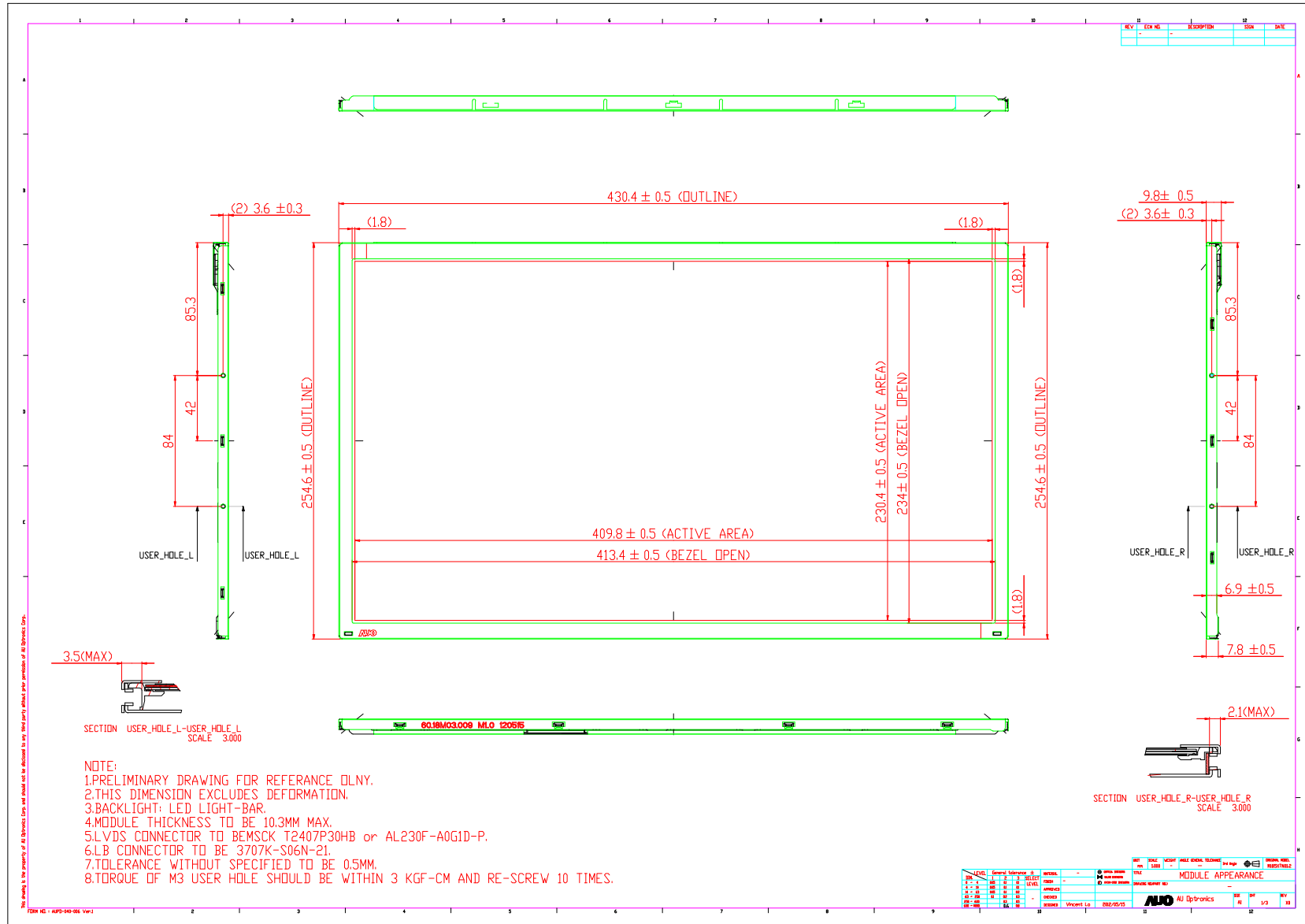

NOTES :

1. THE DIMENSION EXCLUDES DEFORMATION.
2. TOLERANCE WITHOUT NOTICED TO BE  $\pm 0.5MM$ .

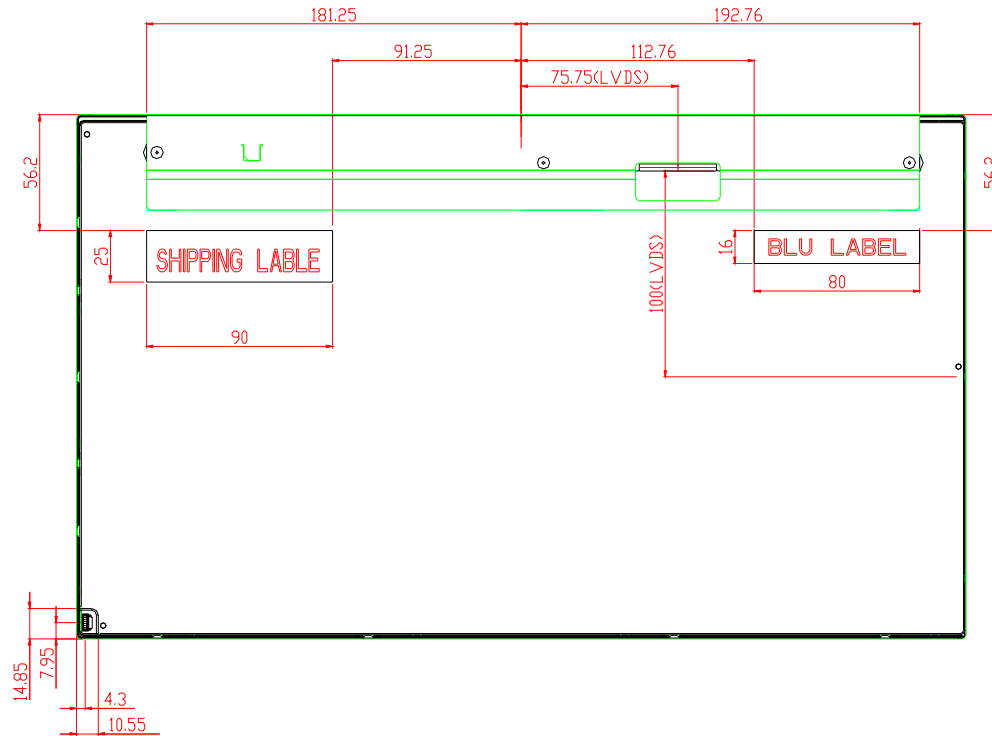

REV	EQ. NO.	DESCRIPTION	BY	DATE

All rights reserved by AU Optonics Corp. All dimensions are in millimeters unless otherwise specified.

REV	EQ. NO.	DESCRIPTION	BY	DATE

NO.	LEVEL	DESCRIPTION	DATE	BY	CHKD.	APPROVED
1	1	INITIAL DESIGN				
2	1	REVISED				
3	1	REVISED				
4	1	REVISED				
5	1	REVISED				
6	1	REVISED				
7	1	REVISED				
8	1	REVISED				
9	1	REVISED				
10	1	REVISED				
11	1	REVISED				
12	1	REVISED				
13	1	REVISED				
14	1	REVISED				
15	1	REVISED				
16	1	REVISED				
17	1	REVISED				
18	1	REVISED				
19	1	REVISED				
20	1	REVISED				
21	1	REVISED				
22	1	REVISED				
23	1	REVISED				
24	1	REVISED				
25	1	REVISED				
26	1	REVISED				
27	1	REVISED				
28	1	REVISED				
29	1	REVISED				
30	1	REVISED				
31	1	REVISED				
32	1	REVISED				
33	1	REVISED				
34	1	REVISED				
35	1	REVISED				
36	1	REVISED				
37	1	REVISED				
38	1	REVISED				
39	1	REVISED				
40	1	REVISED				
41	1	REVISED				
42	1	REVISED				
43	1	REVISED				
44	1	REVISED				
45	1	REVISED				
46	1	REVISED				
47	1	REVISED				
48	1	REVISED				
49	1	REVISED				
50	1	REVISED				
51	1	REVISED				
52	1	REVISED				
53	1	REVISED				
54	1	REVISED				
55	1	REVISED				
56	1	REVISED				
57	1	REVISED				
58	1	REVISED				
59	1	REVISED				
60	1	REVISED				
61	1	REVISED				
62	1	REVISED				
63	1	REVISED				
64	1	REVISED				
65	1	REVISED				
66	1	REVISED				
67	1	REVISED				
68	1	REVISED				
69	1	REVISED				
70	1	REVISED				
71	1	REVISED				
72	1	REVISED				
73	1	REVISED				
74	1	REVISED				
75	1	REVISED				
76	1	REVISED				
77	1	REVISED				
78	1	REVISED				
79	1	REVISED				
80	1	REVISED				
81	1	REVISED				
82	1	REVISED				
83	1	REVISED				
84	1	REVISED				
85	1	REVISED				
86	1	REVISED				
87	1	REVISED				
88	1	REVISED				
89	1	REVISED				
90	1	REVISED				
91	1	REVISED				
92	1	REVISED				
93	1	REVISED				
94	1	REVISED				
95	1	REVISED				
96	1	REVISED				
97	1	REVISED				
98	1	REVISED				
99	1	REVISED				
100	1	REVISED				

REV	EQ. NO.	DESCRIPTION	BY	DATE

## 11. Packing Specification

**M185 14片裝:48.5\*37.2\*34.8cm**

**料號:**

Carton:81.18M02.008 /Cushion:84.18M02.037



將M185模組置入靜電袋中並折疊後  
依序放入包裝隔板中



放置14片，放入上蓋緩衝，封箱完成

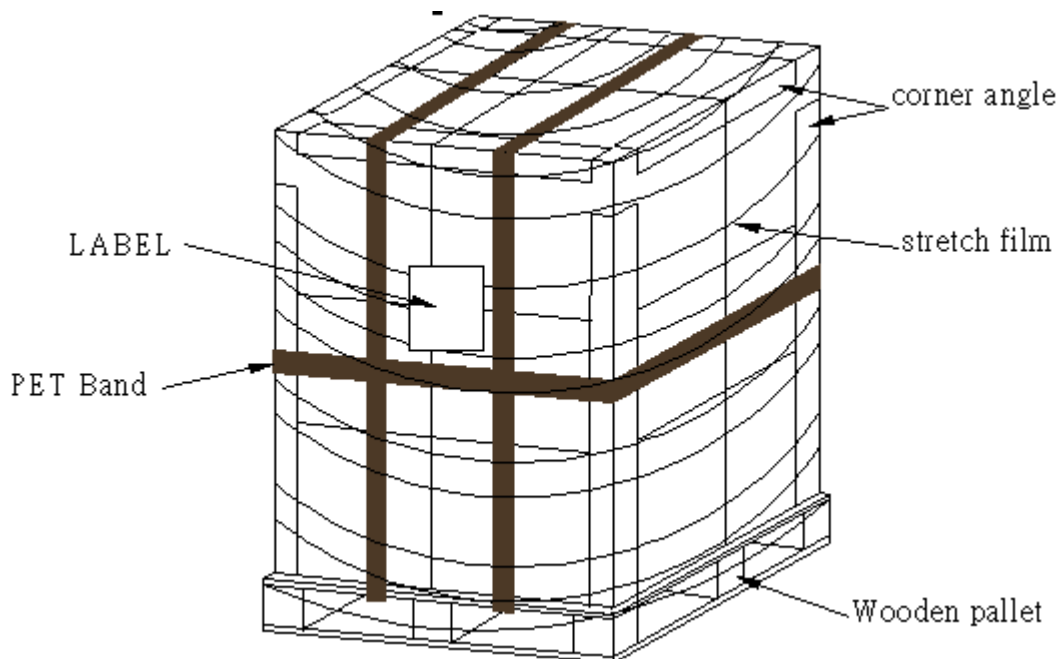
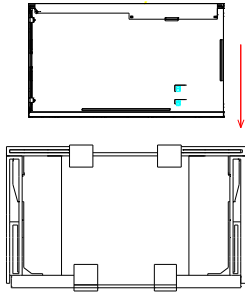

單層 pallet 打棧示意圖



## Pallet and shipment information

	Item	Specification			Remark
		Q'ty	Dimension	Weight(kg)	
1	Panel	1	430.37(H)mm x 254.6(V)mm x 9.9(D)mm	1.330	
2	Cushion	1	-	1.125	
3	Box	1	485(L)mm x 372(W)mm x 348(H)mm	1.00	without Panel & cushion
4	Packing Box	14 pcs/Box	485(L)mm x 372(W)mm x 348(H)mm	20.745	with panel & cushion
5	Pallet	1	1150(L)mm x 980(W)mm x 138(H)mm	15	
6	Pallet after Packing	24 boxes/pallet	1150(L)mm x 980(W)mm x 138(H)mm	509	

**APPENDIX B; RS232  
Communication Protocol**

## RS232 control

**Firmware: 0850-G02205-04**

**RS232 Control instruction:**

- 1.** All commands are comprised of ASCII type 8 bit/no parity/1 stop bit character transmissions, transmitted at 115.2K bit/s as a continuous burst. Duration of the burst must not exceed 20ms. Responses are of a similar format.
- 2.** You need to send 12 X 8bit data to topper, after receiving effective RS232 communication, the Topper will enter the corresponding operation mode (without delay waiting).

**3.** RS232 Communication control protocol as follows,

**Byte1:** Send the lead code(0xe7)

**Byte2:** Send the address code(0x41)

**Byte3:** Send the data length(0x08)

**Byte4-Byte11:** Send mode data of choosing the mode and colour

**Byte12:** Send the chksum data

Byte1	Byte2	Byte3	Byte4- Byte11	Byte12
0xe7	0x41	0x08	Data1-Data8	chksum

- 4.** The chksum field is a negative sum of all preceding bytes of the packet including the flag, total sum of all bytes in the packet is zero.

## 5. Mode and Color select

The **Byte4- Byte11** will decide which mode and color group are used, you need to send 8x8bit data. For certain mode and color group, 0x00 will discard this mode, 0x01-0x05 will enable this mode and color group, see the below diagram:

COLOR	DATA							
	Data1	Data2	Data3	Data4	Data5	Data6	Data7	Data8
	MODE A	MODE B	MODE C	MODE D	MODE E	MODE F	MODE G	MODE H
GWR	0x01	0x01	0x01	ONLY BULE&WHITE WHATEVER 0x01-0x05			0x01	0x01
RGB	0x02	0x02	0x02				0x02	0x02
RYW	0x03	0x03	0x03				0x03	0x03
RWB	0x04	0x04	0x04				0x04	0x04
RCY	0x05	0x05	0x05				0x05	0x05



## 6. Return value

When all data and CRC are received rightly, the controller will return 5 X 8bit data to confirm:

Byte1	Byte2	Byte3	Byte4	Byte5
0xe7	0x41	0x01	Data1	chksum

For example:

The master message might be:

0xe7 0x41 0x08 0x01 0x02 0x03 0x04 0x05 0x01 0x02 0x03 0xBB

The slave reply is just the command echo:

0xe7 0x41 0x01 0x01 0xD6

## 7. Exit RS23 mode

If the topper need to exit RS232 mode, the master controller will send 3 X 8bit data: 0xe7, 0x41 and 0x0D.

## **APPENDIX C; GT4000 EDID Settings**



## EDID ( Extended Display Identification Data) Report

### Vendor/Product Identification:

**Monitor Name :** GM4000-01  
**Monitor Serial Number :**  
**Manufacturer Name :** CNC  
**Product Id :** 0  
**Serial Number :** 6666  
**Week Of Manufacture :** 16  
**Year Of Manufacture :** 2015  
**EDIDVersion :** V1.4  
**Number Of Extension Flag :** 0

### Display parameters:

**Video Input Definition :** Digital Signal  
**DFP1X Compatible Interface :** False  
**Max Horizontal Image Size :** 410 mm  
**Max Vertical Image Size :** 230 mm  
**Max Display Size :** 18.5 Inches

### Power Management and Features:

**Standby :** Supported  
**Suspend :** Supported  
**ActiveOff :** Supported  
**Video Input :** 1  
**sRGB Default ColorSpace :** False  
**Default GTF :** Not Supported  
**Prefered Timing Mode :** True

### Gamma/Color and Established Timings:

**Display Gamma :** 2.2  
**Red :** x = 0.636 - y = 0.349  
**Green :** x = 0.29 - y = 0.584  
**Blue :** x = 0.143 - y = 0.08  
**White :** x = 0.313 - y = 0.329

**Established Timings :**  
 800 x 600 @ 60Hz (VESA)  
 800 x 600 @ 56Hz (VESA)  
 640 x 480 @ 75Hz (VESA)  
 640 x 480 @ 72Hz (VESA)  
 640 x 480 @ 60Hz (IBM, VGA)  
 720 x 400 @ 70Hz (IBM, VGA)  
 1280 x 1024 @ 75Hz (VESA)  
 1024 x 768 @ 75Hz (VESA)  
 1024 x 768 @ 70Hz (VESA)  
 1024 x 768 @ 60Hz (VESA)  
 800 x 600 @ 75Hz (VESA)  
 800 x 600 @ 72Hz (VESA)

**Display Type :** RGB Color Display

### Standard Timing:

**Standard Timings n°** 2

X Resolution : 1280  
 Y Resolution : 960  
 Vertical Frequency : 60

Standard Timings n° 3  
 X Resolution : 1152  
 Y Resolution : 864  
 Vertical Frequency : 60

Standard Timings n° 4  
 X Resolution : 1600  
 Y Resolution : 900  
 Vertical Frequency : 60

Standard Timings n° 5  
 X Resolution : 1280  
 Y Resolution : 1024  
 Vertical Frequency : 60

Standard Timings n° 8  
 X Resolution : 1920  
 Y Resolution : 1080  
 Vertical Frequency : 60

### Preferred Detailed Timing:

Pixel Clock : 85.5 Mhz

Horizontal Active : 1366 pixels  
 Horizontal Blanking : 426 pixels  
 Horizontal Sync Offset : 70 pixels  
 Horizontal Sync Pulse Width : 143 pixels  
 Horizontal Border : 0 pixels  
 Horizontal Size : 426 mm

Vertical Active : 768 lines  
 Vertical Blanking : 30 lines  
 Vertical Sync Offset : 3 lines  
 Vertical Sync Pulse Width : 3 lines  
 Vertical Border : 0 lines  
 Vertical Size : 239 mm

Input Type : Digital Separate  
 Interlaced : False  
 VerticalPolarity : True  
 HorizontalPolarity : True

### Detailed Timing #2:

Pixel Clock : 74.25 Mhz

Horizontal Active : 1280 pixels  
 Horizontal Blanking : 370 pixels  
 Horizontal Sync Offset : 110 pixels  
 Horizontal Sync Pulse Width : 220 pixels  
 Horizontal Border : 0 pixels  
 Horizontal Size : 425 mm

Vertical Active : 720 lines  
 Vertical Blanking : 30 lines  
 Vertical Sync Offset : 5 lines  
 Vertical Sync Pulse Width : 20 lines  
 Vertical Border : 0 lines  
 Vertical Size : 239 mm

**Input Type :** Digital Separate  
**Interlaced :** False  
**VerticalPolarity :** True  
**HorizontalPolarity :** True

**Monitor Range Limit:**

**Maximum Vertical Frequency :** 76 Hz  
**Minimum Vertical Frequency :** 55 Hz  
**Maximum Horizontal Frequency :** 85 KHz  
**Minimum Horizontal Frequency :** 30 KHz  
**Maximum Pixel Clock :** 140 MHz

**Stereo Display:**

**Stereo Display :** Normal display (no stereo)

**RAW Data:**

```
0x00  00 FF FF FF FF FF FF 00 0D C3 00 00 0A 1A 00 00
0x10  10 19 01 04 80 29 17 78 EA D6 A5 A2 59 4A 95 24
0x20  14 50 54 AF CF 00 81 00 81 40 71 40 A9 C0 81 80
0x30  95 00 B3 00 D1 C0 66 21 56 AA 51 00 1E 30 46 8F
0x40  33 00 AA EF 10 00 00 1E 01 1D 00 72 51 D0 1E 20
0x50  6E DC 54 01 A9 EF 10 00 00 1E 00 00 00 FC 00 47
0x60  4D 34 30 30 30 2D 30 31 0A 20 20 20 00 00 00 FD
0x70  00 37 4C 1E 55 0E 00 0A 20 20 20 20 20 00 7D
```



# Gamesman

**GAMESMAN LTD**  
**CROMPTON FIELDS, CROMPTON WAY, CRAWLEY, WEST SUSSEX, RH10 9QB**  
**TEL: +44 (0) 1293 418888 FAX: +44 (0) 1293 418880**

REGISTERED IN ENGLAND NO. 3027138

Website: [www.gamesman.co.uk](http://www.gamesman.co.uk)  
Email: [sales@gamesman.co.uk](mailto:sales@gamesman.co.uk)